

Group Standard

VW 80000

Issue 2017-10

Class. No. 8MA00

Descriptors: component, electric component, electronic component, module, test condition

Electric and Electronic Components in Motor Vehicles up to 3.5 t General Requirements, Test Conditions, and Tests

Previous issues

VW 80101: 1987-06, 1988-08, 1992-01, 1993-04, 1994-05, 1995-06, 1998-01, 1999-06, 2000-09, 2001-04, 2003-05, 2004-07, 2005-06, 2006-10, 2009-03; VW 80000: 2009-10, 2013-06

Changes

The following changes have been made compared to Volkswagen standard VW 80000, 2013-06:

- See change history on page 2

Always use the latest version of this standard.

This electronically generated standard is authentic and valid without a signature.

The English translation is believed to be accurate. In case of discrepancies, the German version controls.

Page 1 of 165

Technical responsibility		Standards	
EEIP/1	Dr. Torsten Polte	Phone: +49 5361 9 36035	
I/EE-61	Uwe Girgsdies	Phone: +49 841 89 90836	K-ILI/5 Dirk Beinker
EEG4	Mark Martins	Phone: +49 711 911 84847	Phone: +49 5361 9 32438
			K-ILI Uwe Wiesner

All rights reserved. No part of this document may be provided to third parties or reproduced without the prior consent of one of the Volkswagen Group's Standards departments.

© Volkswagen AG

WVNORM-2016-08a

Revision record

Date of issue	
2013-02	<p data-bbox="432 324 877 362">Editorial changes incorporated.</p> <p data-bbox="432 398 1362 470">Part I – Electrical requirements and tests on the 12-V electric system:</p> <p data-bbox="432 472 1212 544">Thoroughly revised – each test was adapted to current requirements.</p> <p data-bbox="432 582 1155 620">Part II – Environmental requirements and tests:</p> <p data-bbox="432 622 1358 728">Expanded to components that are described in several operating situations and components that are connected to coolant circuits; service life tests revised</p>
2017-05	<p data-bbox="432 728 742 766">Fundamental revision</p> <p data-bbox="432 801 555 840">General</p> <ul data-bbox="480 842 1409 949" style="list-style-type: none">- Operating modes and their derivation and designation revised- General requirements for part I and part II harmonized and merged <p data-bbox="432 985 1362 1057">Part I – Electrical requirements and tests on the 12-V electric system:</p> <ul data-bbox="480 1059 1398 1317" style="list-style-type: none">- Expanded to include function classes- Functional states reorganized- Vehicles with alternative drives taken into account- Parameter tests redefined- E-03b, E-07b, and E-23 added- General modifications and error corrections (consideration of all change requests (CRs) received) <p data-bbox="432 1352 1155 1391">Part II – Environmental requirements and tests:</p> <ul data-bbox="480 1393 1294 1496" style="list-style-type: none">- Expansions to test procedures in the individual tests- Leak tightness requirement expanded- Pressure pulsation test added to the mechanical tests

Contents

1	Scope	6
2	Referenced standards	7
3	Terms and definitions	9
3.1	Terms and abbreviations	9
3.2	Voltages and currents	11
3.3	Temperatures	12
3.4	Times	12
3.5	Internal resistance, terminal designation, frequency	12
3.6	Standard tolerances	13
3.7	Standard values	13
4	General requirements	14
4.1	Sampling rates and measured-value resolutions	14
4.2	Functional states	14
4.3	Operating situations	15
4.4	Operating states	15
4.5	Operating modes	16
4.6	Temperature stabilization	19
4.7	Parameter test	20
4.8	Continuous parameter monitoring with drift analysis	22
4.9	Leak tightness	23
Part I – Electrical requirements and tests on the 12-V electric system		24
5	General requirements	24
5.1	Voltages and currents	24
5.2	Test voltages	24
5.3	Function classes and operating voltage ranges	25
5.4	Interface description	25
5.5	Procedure restrictions	25
5.6	Test sequence	26
6	Test selection table	28
7	Electrical requirements and tests	30
7.1	E-01 Long-term overvoltage	30
7.2	E-02 Transient overvoltage	32
7.3	E-03 Transient undervoltage	34
7.4	E-04 Jump start	37
7.5	E-05 Load dump	38
7.6	E-06 Ripple voltage	39
7.7	E-07 Slow decrease and increase of the supply voltage	41
7.8	E-08 Slow decrease, quick increase of the supply voltage	44
7.9	E-09 Reset behavior	46
7.10	E-10 Brief interruptions	48
7.11	E-11 Start pulses	51
7.12	E-12 Voltage curve with electric system control	55
7.13	E-13 Pin interruption	56
7.14	E-14 Connector interruption	58
7.15	E-15 Reverse polarity	59
7.16	E-16 Ground potential difference	62
7.17	E-17 Short circuit in signal line and load circuits	63

7.18	E-18 Insulation resistance.....	65
7.19	E-19 Quiescent current	66
7.20	E-20 Dielectric strength.....	67
7.21	E-21 Backfeeds.....	68
7.22	E-22 Overcurrents.....	70
7.23	E-23 Equalizing currents of multiple supply voltages	71
Part II – Environmental requirements and tests		73
8	Use profile	73
8.1	Service life requirements.....	73
8.2	Temperature load spectra	73
9	Test selection	75
9.1	Test selection table	75
9.2	Test sequence plan.....	77
10	Mechanical requirements and tests	78
10.1	M-01 Free fall.....	78
10.2	M-02 Stone impact test	79
10.3	M-03 Dust test.....	80
10.4	M-04 Vibration test.....	81
10.5	M-05 Mechanical shock	92
10.6	M-06 Continuous mechanical shock	93
10.7	M-07 Coolant circuit pressure pulsation test	94
11	Climatic requirements and tests.....	95
11.1	K-01 High-/low-temperature aging	95
11.2	K-02 Incremental temperature test.....	96
11.3	K-03 Low-temperature operation	98
11.4	K-04 Repainting temperature	99
11.5	K-05 Thermal shock (component).....	100
11.6	K-06 Salt spray test with operation, exterior.....	101
11.7	K-07 Salt spray test with operation, interior.....	103
11.8	K-08 Damp heat, cyclic	104
11.9	K-09 Damp heat, cyclic (with frost)	105
11.10	K-10 Water protection – IPX0 to IPX6K	106
11.11	K-11 High-pressure cleaning/pressure washing.....	107
11.12	K-12 Thermal shock with splash water.....	108
11.13	K-13 Thermal shock – immersion	111
11.14	K-14 Damp heat, constant	111
11.15	K-15 Condensation and climatic test.....	115
11.16	K-16 Thermal shock (without housing).....	123
11.17	K-17 Solar radiation	124
11.18	K-18 Harmful gas test	125
12	Chemical requirements and tests.....	126
12.1	C-01 Chemical tests.....	126
13	Service life tests.....	129
13.1	L-01 Service life test – Mechanical/hydraulic durability testing	129
13.2	L-02 Service life test – High-temperature durability testing	131
13.3	L-03 Service life test – Temperature cycle durability testing	135
Appendix A (normative) Test sequence		140
A.1	Test sequence plan.....	140
A.2	Sequence tests	141

A.3	Tests outside of the sequence (parallel tests).....	143
A.4	Service life tests.....	145
Appendix B (normative) Typical temperature load spectra for different installation areas.....		146
B.1	Temperature load spectrum 1.....	147
B.2	Temperature load spectrum 2.....	147
B.3	Temperature load spectrum 3.....	147
B.4	Temperature load spectrum 4.....	147
Appendix C (normative) Calculation for the performance of the "Mechanical/hydraulic durability testing" service life test.....		148
C.1	Calculation.....	148
C.2	Example calculation.....	150
Appendix D (normative) Calculation models for the "High-temperature durability testing" service life test.....		152
D.1	Adaptation of the test temperatures to reduce the test duration.....	152
D.2	Arrhenius model.....	152
D.3	Example Arrhenius model:.....	154
D.4	Arrhenius model to be used for components with reduced performance at high temperatures.....	155
D.5	Example Arrhenius model to be used for components with reduced performance at high temperatures:.....	156
D.6	Arrhenius model to be used for components on coolant circuits.....	158
D.7	Example Arrhenius model to be used for components on coolant circuits.....	163
Appendix E (normative) Calculation models for the "Temperature cycle durability testing" service life test.....		166
E.1	Adaptation of the test temperatures to reduce the test cycles.....	166
E.2	Coffin-Manson model.....	166
E.3	Example:.....	168
E.4	Coffin-Manson model to be used for components on coolant circuits.....	169
E.5	Example Coffin-Manson model to be used for components on coolant circuits.....	172
Appendix F (normative) Calculation models for the "Damp heat, constant – severity 2" test.....		174
F.1	Lawson model.....	174
F.2	Example:.....	175
Appendix G (informative) Condensation test, chamber programming, and graphs.....		176
Appendix H Examination methods for physical analysis.....		179

1 Scope

This document specifies requirements, test conditions, and tests for electric, electronic, and mechatronic components and systems for use in motor vehicles up to 3.5 t.

Additional or deviating requirements, test conditions, and tests are defined in the corresponding Performance Specifications.

The following additionally applies to part I: The requirements, test conditions, and tests refer to the 12-V electric system. Unless otherwise noted, the tests are not electrical service life tests.

Note: The specified tests are used to check some of the required properties of the component and are not used for subcomponent qualification or qualification of the production process.

2 Referenced standards

Table 1: Referenced standards

ANSI/UL 94	Standard for Tests for Flammability of Plastic Materials for Parts in Devices and Appliances
DIN 75220	Ageing of Automotive Components in Solar Simulation Units
DIN 72552-2	Terminal Markings for Vehicles – Part 2: Codes
DIN EN 13018	Non-Destructive Testing – Visual Testing – General Principles
DIN EN ISO/IEC 17025	General Requirements for the Competence of Testing and Calibration Laboratories
DIN EN 60068-2-1	Environmental Testing – Part 2-1: Tests – Test A: Cold
DIN EN 60068-2-2	Environmental Testing – Part 2-2: Tests – Test B: Dry Heat
DIN EN 60068-2-6	Environmental Testing – Part 2-6: Tests – Test Fc: Vibration (Sinusoidal)
DIN EN 60068-2-11	Environmental Testing – Part 2: Tests – Test Ka: Salt Mist
DIN EN 60068-2-14	Environmental Testing – Part 2-14: Tests – Test N: Change of Temperature
DIN EN 60068-2-27	Environmental Testing – Part 2-27: Tests – Test Ea and Guidance: Shock
DIN EN 60068-2-29	Basic Environmental Testing Procedures – Part 2: Tests; Test Eb and Guidance: Bump
DIN EN 60068-2-30	Environmental Testing – Part 2-30: Tests – Test Db: Damp Heat, Cyclic (12 h + 12 h Cycle)
DIN EN 60068-2-38	Environmental Testing – Part 2-38: Tests – Test Z/AD: Composite Temperature/Humidity Cyclic Test
DIN EN 60068-2-60	Environmental Testing – Part 2-60: Tests – Test Ke: Flowing Mixed Gas Corrosion Test
DIN EN 60068-2-64	Environmental Testing – Part 2-64: Tests – Test Fh: Vibration, Broadband Random and Guidance
DIN EN 60068-2-78	Environmental Testing – Part 2-78: Tests – Test Cab: Damp Heat, Steady State
DIN EN ISO 11124-2	Preparation of Steel Substrates Before Application of Paints and Related Products – Specifications for Metallic Blast-Cleaning Abrasives – Part 2: Chilled-Iron Grit
DIN EN ISO 20567-1	Paints and Varnishes – Determination of Stone-Chip Resistance of Coatings – Part 1: Multi-Impact Testing
DIN EN ISO 6270-2	Paints and varnishes - Determination of resistance to humidity - Part 2: Condensation (in-cabinet exposure)
ISO 12103-1	Road Vehicles – Test Contaminants for Filter Evaluation – Part 1: Arizona Test Dust
ISO 16750-3	Road Vehicles – Environmental Conditions and Testing for Electrical and Electronic Equipment – Part 3: Mechanical Loads
ISO 16750-5	Road Vehicles – Environmental Conditions and Testing for Electrical and Electronic Equipment – Part 5: Chemical Loads

ISO 20653	Road Vehicles – Degrees of Protection (IP Code) – Protection of Electrical Equipment Against Foreign Objects, Water and Access
ISO 26262	Road Vehicles – Functional Safety

3 Terms and definitions

3.1 Terms and abbreviations

Table 2: Abbreviations for electrical requirements and tests

Term/abbreviation	Definition
Application software	Relates to the behavior according to the function class as per this standard and the functional capabilities as per the Performance Specification, for example: <ul style="list-style-type: none"> • Startup behavior • Sleep behavior • Control systems • Overload protection, short-circuit protection, and fiddle-proofing • Diagnostics
Module	Electronic circuit carrier populated with subcomponents (without the housing)
Subcomponent/subcomponents	Electric, electronic, or mechatronic subcomponent (e.g., resistor, capacitor, transistor, integrated circuit (IC), relay)
Operation (general)	Out of all relevant situations, operating situation in which minimum or maximum self-heating is generated. This operating situation is additionally defined.
DAE	Venting element
Derating	Deliberately limited function, e.g., change in power consumption as a function of voltage and/or temperature
DUT	See "Device under test"
Driving	Operating situation of a vehicle that has been released and put into operation by the customer (terminal 15 (t.15) on). A vehicle with an electric drive is not connected to a charging station/socket-outlet.
Assembly	Operating situation that reflects the assembly process. A distinction is made at the component level between an disconnected connector ("not installed") and a connected connector ("assembly"). In both cases, the component is free of voltage and current.
Functions	Includes system-specific functions and diagnostic functions
Hardware freeze	The point during development from which changes to the hardware are no longer possible
ICT	In-circuit test
High availability	For its function, the component needs a requirement of at least ASIL A as per ISO 26262 for the electrical power supply (ASIL – Automotive Safety Integrity Level).

Climatic chamber with condensation option	<p>A specially controlled water bath in the climatic chamber, by means of which the required water quantity is implemented in the form of water vapor.</p> <p>The intensity of the condensation film on the circuit carrier depends on the thermal capacity, the relative humidity, and the temperature gradient of the water bath.</p> <p>The climate control of the climatic chamber is switched off during the condensation phase. The test chamber temperature is controlled by means of the temperature-controlled water bath.</p>
Component	Complete device, electronic control unit (ECU), or mechatronic system (including housing)
Short circuit	<p>A short circuit of a load output is defined by a loading case with lower impedance than with the specified load, down to the limit case of 0 Ω. This includes a creeping short circuit, that is, with the current just below short-circuit detection.</p> <p>A short circuit may be permanently present (component in operation/not in operation).</p>
Charging	Operating situation of a vehicle with an electric drive that is parked and connected to a charging station/socket-outlet. The high-voltage battery pack is charging.
Performance Specification	<p>Used in this standard as a generic term for the following, for example:</p> <ul style="list-style-type: none"> • Drawing • Component Performance Specification (BT-LAH) • Feature Performance Specification • General Project-Independent Performance Specification (Q-LAH) • System Performance Specification • Reliability Testing Performance Specification • Diagnostics Performance Specification • Electromagnetic Compatibility (EMC) Performance Specification • Quality Performance Specification
On-grid parking	Operating situation of a vehicle with an electric drive that is parked and connected to a charging station/socket-outlet. The high-voltage battery pack is not charging. The vehicle can communicate with the charging station; a charging process is complete or can be started at any time. Extended use of the high-voltage battery pack is possible, e.g., as a buffer store by the power-grid operator.
Off-grid parking	Operating situation of a vehicle that is parked. A vehicle with an electric drive is not connected to a charging station/socket-outlet.
Power user	Actual use case with maximum conceivable utilization
Device under test	The system or component being tested
PTB	The National Metrology Institute of Germany (Physikalisch-Technische Bundesanstalt)
PSD	Power spectral density

Circuit carrier	Unpopulated substrate for electronics in general (unpopulated printed circuit board (PCB), ceramic, lead frame, flexible PCB/connector, etc.)
Relevant to starting	Components that are needed directly or indirectly for the starting process of an internal combustion engine
System	Functionally linked components, e.g., brake control system (control module, hydraulic system, sensors)
Preconditioning	Operating situation of a vehicle with an electric drive that is parked and can be connected to a charging station/socket-outlet. The vehicle executes thermal conditioning. This typically involves vehicle-interior conditioning and/or high-voltage battery pack conditioning.

3.2 Voltages and currents

Table 3: Abbreviations for voltages and currents

V_N	Nominal voltage
V_{opmin}	Minimum operating voltage limit
V_{op}	Operating voltage
V_{opmax}	Maximum operating voltage limit
V_{max}	Maximum voltage that can occur during a test
V_{min}	Minimum voltage that can occur during a test
V_{PP}	Peak-to-peak voltage
V_{RMS}	Root-mean-square (RMS) value of a voltage
V_{test}	Test voltage
I_N	Nominal current
GND	Device ground
V_A, V_T, V_S, V_R	Voltage level of the starting voltage pulse

3.2.1 Voltages for components with extended requirements

Table 4: Abbreviations for extended voltage definitions

$V_{opmin,HV}$	Minimum high-voltage (HV) operating voltage limit – minimum direct-current (DC) operating voltage
$V_{op,HV}$	Operating voltage HV DC operating voltage
$V_{opmax,HV}$	Maximum HV operating voltage limit – maximum DC operating voltage

3.3 Temperatures

Table 5: Abbreviations for temperatures

T_{\min}	Minimum ambient temperature
T_{RT}	Room temperature
T_{\max}	Maximum ambient temperature
$T_{op,\min}$	Minimum ambient temperature for components with overload protection/low-temperature protection at which full functionality is still required
$T_{op,\max}$	Maximum ambient temperature for components with overload protection/overtemperature protection at which full functionality is still required
T_{test}	Test temperature

3.3.1 Temperatures for components of a coolant circuit

Table 6: Coolant circuit temperature definitions

$T_{\text{cool,nom}}$	Nominal coolant temperature in the coolant circuit
$T_{\text{cool,min}}$	Minimum coolant temperature in the coolant circuit
$T_{\text{cool,max}}$	Maximum coolant temperature in the coolant circuit

3.4 Times

Table 7: Abbreviations for times

t_{test}	Test duration
$t_{\text{operation}}$	Operating duration over the service life
t_r	Rise time (e.g., of a voltage curve)
t_f	Fall time (e.g., of a voltage curve)

3.5 Internal resistance, terminal designation, frequency

Table 8: Abbreviations for resistances, terminals, and frequencies

R_i	Internal resistance of the source, including the power supply wiring harness (see section 5.1)
Terminal designations	As per DIN 72552-2
f	Frequency

3.6 Standard tolerances

Unless otherwise specified, the tolerances specified in Table 9 apply. The tolerances have reference to the required measured value.

Table 9: Standard tolerances

Frequencies	±1%
Temperatures	±2 °C
Humidity	±5%
Times	+5%; 0%
Voltages	±2%
Currents	±2%
Vibrations	±3 dB
Vibration PSD	±5%

3.7 Standard values

Unless otherwise specified, the standard values specified in Table 10 apply.

Table 10: Standard values

Room temperature	$T_{RT} = 23 \text{ °C} \pm 5 \text{ °C}$
Humidity	$H_{rel} = 25\% \text{ to } 75\% \text{ relative humidity}$
Test temperature	$T_{test} = T_{RT}$
Operating voltage (for test)	$V_{op} = 14 \text{ V}$

4 General requirements

4.1 Sampling rates and measured-value resolutions

The sampling rate or bandwidth of the measuring system must be adapted to the DUT in question. All measured values must be recorded with all maximum values (peaks).

The resolution of the measured values must be adapted to the test in question. It must be ensured that voltage peaks do not lead to an overflow and that there will not be cases in which they cannot be measured due to insufficient resolution. Data reduction/abstraction (e.g., limit monitoring, bus-message evaluation) must not suppress irregularities.

4.2 Functional states

4.2.1 General

This section describes the functional state of the DUT before, during, and after the test. The purchaser must define the functional behavior (including derating, e.g., in terms of temperature and voltage) of the component in the functional states, as well as the customer's perception (e.g., visual, acoustic, tactile, thermal) in the drawing or in the Performance Specification.

Memory functions must always remain in functional state A, in all cases. The integrity of non-volatile memories must be guaranteed at all times. The time sequences of the functional states must be indicated in the Performance Specification. Permitted event memory entries must be agreed upon with the purchaser and must be recorded in writing.

Damage to the DUT is not permissible in functional states A to D. Undefined functions are not permissible at any time. The permissible limits (e.g., electrical, thermal, mechanical) for the electrical/electronic components installed in the DUT, as specified in the data sheets, must not be exceeded. This is verified at least by the P-02 Parameter test (small) specified in section 4.7.2.

4.2.2 Functional state A

The DUT fulfills all functions as specified.

4.2.3 Functional state B

Not used.

4.2.4 Functional state C

The DUT does not fulfill one or more functions during exposure to the test parameters. After exposure to the test parameters, the DUT must immediately return to functional state A automatically or by means of the external triggers specified in the Performance Specification. Undefined functions are not permissible at any time.

4.2.5 Functional state D1

The DUT does not fulfill one or more functions during exposure to the test parameters. After exposure to the test parameters, the DUT must return to functional state A by means of terminal on/off switching (if necessary, with bus idle).

4.2.6 Functional state D2

The DUT does not fulfill one or more functions during exposure to the test parameters. After exposure to the test parameters, the DUT must return to functional state A by means of a simple intervention (e.g., replacement of a faulty fuse).

4.2.7 Functional state E

The DUT does not fulfill one or more functions during exposure to the test parameters and must be repaired or replaced after exposure to the test parameters. The DUT must fulfill flame-retardant classification V-0 as per UL 94 published by Underwriters Laboratories.

4.3 Operating situations

For vehicles with a powertrain driven by an internal combustion engine only, vehicle operation can usually be divided into the following operating situations over its service life:

- Driving
- Parking (referred to as "off-grid parking" in this document)
- Assembly
- Operation (general)

For vehicles with an electric drive, additional operating situations must be taken into account as needed:

- Charging
- Preconditioning
- On-grid parking

All operating situations relevant to the component must be taken into account when deriving the test requirements.

4.4 Operating states

4.4.1 General

To facilitate a reproduction during the tests of the various component loads that occur in real-life situations, the following operating states are defined.

If additional operating states are relevant to the component, they must be defined together with the purchaser.

4.4.1.1 Operating state – Not electrically connected

The DUT is free of voltage and current. If a coolant circuit is present, it is not filled and its connections are sealed.

A distinction is made between

- "not installed": DUT without connector and wiring harness
- "assembly": DUT with connected connector and wiring harness

4.4.1.2 Operating state – Electrically connected and low operating load

The DUT must be operated with the lowest possible real-life operating load for the operating situation in question. This may also mean that the DUT is operated without an operating load.

The voltage supply of all voltage levels relevant to the component (12-V electric system, 48-V electric system, HV_{AC}, and HV_{DC}) and, if applicable, the bus activity, must be recreated according to the actual situation in the vehicle for the operating situation in question.

If a coolant circuit is present, it must be filled, and the coolant hoses must be connected. The flow rate and temperature of the coolant must be adjusted as required, as defined in the Performance Specification.

This operating state is identified by "min" in this document.

4.4.1.1 Operating state – Electrically connected and high operating load

The DUT must be operated with the maximum operating load as per the design load profile (power user, but no misuse).

The DUT must be operated in such a way that it generates a maximum power loss (e.g., by means of a realistic maximization of a continuous output power or by means of frequent activation of external loads).

The voltage supply of all voltage levels relevant to the component (12-V electric system, 48-V electric system, HV_{AC}, and HV_{DC}) and, if applicable, the bus activity, must be recreated according to the actual situation in the vehicle for the operating situation in question.

If a coolant circuit is present, it must be filled, and the coolant hoses must be connected. The flow rate and temperature of the coolant must be adjusted as required, as defined in the Performance Specification.

This operating states is identified by "max" in this document.

4.5 Operating modes

4.5.1 General

The following applies in general:

The operating mode of the component is yielded from the allocation of the operating states to the respective operating situations (Operating situation_{operating state}).

Details concerning the operating modes, operating loads (e.g., activation, bus activity, bus messages, original sensors, original actuators, substitute circuits), and the required general conditions must be agreed upon between the purchaser and contractor, and documented.

4.5.2 Operating modes for operating state "Not electrically connected"

Operating state "Not electrically connected" is allocated to operating situation "Assembly." A distinction is made between the following operating modes of the component:

- Assembly_{not installed}:

Note: This operating mode was referred to as "I.a" in earlier versions of this document.

- Assembly_{assembly}:

Note: This operating mode was referred to as "I.b" in earlier versions of this document.

4.5.3 Operating modes for operating state "Electrically connected and low operating load"

Operating state "Electrically connected and low operating load" is allocated to operating situations "Driving," "Charging," "Preconditioning," "On-grid parking," and "Off-grid parking." This yields the following operating modes:

- Driving_{min}
- Charging_{min}
- Preconditioning_{min}
- On-grid parking_{min}
- Off-grid parking_{min}

Out of these operating modes with low operating load, the operating mode during which the component generates the least power loss must be determined. This is defined in addition to the other operating modes, and referred to as:

- Operation_{min}

If there are multiple operating modes with low operating load during which the component generates power loss or has specific functions, the component must be operated in these operating modes intermittently; all functions of the relevant operating modes must be taken into account here.

4.5.4 Operating modes for operating state "Electrically connected and high operating load"

Operating state "Electrically connected and high operating load" is allocated to operating situations "Driving," "Charging," "Preconditioning," "On-grid parking," and "Off-grid parking." This yields the following operating modes:

- Driving_{max}
- Charging_{max}
- Preconditioning_{max}
- On-grid parking_{max}
- Off-grid parking_{max}

Out of these operating modes with high operating load, the operating mode during which the component generates the greatest power loss must be determined. This is defined in addition to the other operating modes, and referred to as:

- Operation_{max}

If there are multiple operating modes with high operating load during which the component generates a significant power loss or has specific functions, the component must be operated in these operating modes intermittently; all functions of the relevant operating modes must be taken into account here.

4.5.5 Overview of operating modes

Table 11: Classification and designation of operating modes

Operating situation	Operating mode: Not electrically connected	Operating mode: Electrically connected and low operating load	Operating mode: Electrically connected and high operating load
Assembly	Assembly _{not installed} (formerly I.a)		
	Assembly _{assembly} (formerly I.b)		
Driving		Driving _{min}	Driving _{max}
Charging		Charging _{min}	Charging _{max}
Preconditioning		Preconditioning _{min}	Preconditioning _{max}
On-grid parking		On-grid parking _{min}	On-grid parking _{max}
Off-grid parking		Off-grid parking _{min}	Off-grid parking _{max}
General		Operation _{min}	Operation _{max}

4.5.6 Application of the operating modes

The operating modes for the component in question must be defined and agreed upon with the purchaser in line with Table 11, before the start of reliability testing.

Table 12: Example operating modes – DUT electrically connected

Operating mode	Car stereo with navigation system	Anti-theft alarm system	On-board charger
Driving _{min}	Component switched off by driver, bus/microcontrollers active	No function	No function, voltage supplies (12-V electric system and, if applicable, HV _{DC}) applied
Driving _{max}	Component switched on (data buses, electronic drives, navigation system, final stages), active	No function	No function, voltage supplies (12-V electric system and, if applicable, HV _{DC}) applied

Charging _{min}	Not relevant	Not relevant	Charging process with low charging power, voltage supplies (12-V electric system, HV _{AC} , and HV _{DC}) applied
Charging _{max}			Charging process with high charging power, voltage supplies (12-V electric system, HV _{AC} , and HV _{DC}) applied
Preconditioning _{min}			No charging process, voltage supply to components necessary for preconditioning with low power, voltage supplies (12-V electric system, HV _{AC} , and HV _{DC}) applied
Preconditioning _{max}			No charging process, voltage supply to components necessary for preconditioning with high power, voltage supplies (12-V electric system, HV _{AC} , and HV _{DC}) applied
On-grid parking _{min}			No charging process, power-line communication active
On-grid parking _{max}			
Off-grid parking _{min}	Component in sleep mode, post-run ended	Deactivated by customer, no function	No charging process, voltage supply (only 12-V electric system) applied
Off-grid parking _{max}	Component switched on (data buses, electronic drives, navigation system, final stages), active	Function active	
Operation _{min}	Component in sleep mode, post-run ended (corresponds to "Off-grid parking _{min} ")	No function (corresponds to "Driving _{min} ")	No charging process, voltage supply (only 12-V electric system) applied (corresponds to "Off-grid parking _{min} ")
Operation _{max}	Component switched on (data buses, electronic drives, navigation system, final stages), active (corresponds to "Driving _{max} ", "Off-grid parking _{max} ")	Function active (corresponds to "Off-grid parking _{max} ")	Charging process with high charging power, voltage supplies (12-V electric system, HV _{AC} , and HV _{DC}) applied (corresponds to "Charging _{max} ")

4.6 Temperature stabilization

A component exposed to a constant ambient temperature under defined operating conditions is said to be thermally stabilized from the point in time that the temperature does not vary by more than ± 3 °C at any point of the component over the course of time going forward.

The contractor must determine the time until complete temperature stabilization is achieved through experiments, and indicate it in the test documentation.

For temperature cycle tests, after reaching a temperature-stabilized state, the DUTs must additionally be kept at the specified temperature reference values for a defined period, so that stresses in the component can be converted into elongations. This additional hold time must be indicated for the respective tests.

4.7 Parameter test

A set of sensitive parameters, or "key" parameters, such as the quiescent-current draw, operating currents, output voltages, contact resistances, input impedances, signal rates (rise and fall times), and bus specifications, must be defined in the Performance Specification. These parameters must be checked before the start of each test, and at the conclusion of each test, in terms of their compliance with specifications. For components connected to the coolant circuit, the parameter tests must be performed at T_{RT} with $T_{cool,nom}$, at T_{max} with $T_{cool,max}$, and at T_{min} with $T_{cool,min}$. Unless otherwise specified in the Performance Specification, the parameter tests must be performed at V_{opmin} with $V_{opmin,HV}$, at V_{op} with $V_{op,HV}$, and at V_{opmax} with $V_{opmax,HV}$ for components with an HV supply.

The parameter test must be performed immediately upon completion of the test. The time between the end of the test and the performance of the parameter test must be documented in the test report.

4.7.1 P-01 Parameter test (function check)

4.7.1.1 Purpose

The parameter test (function check) is meant to provide evidence of a DUT's flawless function at a specified temperature and at voltages V_{opmin} , V_{op} , and V_{opmax} .

4.7.1.2 Test

The key parameters must be measured and recorded. The functional behavior at a specified temperature and at each of the voltages V_{opmin} , V_{op} , and V_{opmax} must be checked.

The basic functionalities of the components must be measured.

For components with an event memory, the content of the event memory must be read out.

4.7.1.3 Requirement

Functional state A.

Changes in the values of the key parameters, the basic functionality of the component, or the event memory entries must be evaluated in terms of the preceding test loads as compared to the unused condition.

The results must be documented in the test report.

4.7.2 P-02 Parameter test (small)

4.7.2.1 Purpose

The parameter test (small) is meant to provide evidence of a DUT's flawless function at room temperature and operating voltage.

4.7.2.2 Test

The key parameters must be measured and recorded. The functional behavior of the components at T_{RT} and V_{op} must be checked.

The components must be checked in the context of a visual inspection as per DIN EN 13018.

For components with an event memory, the content of the event memory must be read out and documented. The event memory entry must then be cleared.

The test sequence and the results must be documented.

4.7.2.3 Requirement

Functional state A.

Changes in the values of the key parameters, the functional behavior, or the event memory entries, as well as irregularities in the visual inspection, must be evaluated in terms of the preceding test loads as compared to the unused condition.

The visual inspection must evaluate any external damage or changes, such as cracks, ruptures, flaking, discoloration, and deformation. Visual irregularities are not permissible.

There must not be any loose parts inside the device.

4.7.3 P-03 Parameter test (large)

4.7.3.1 Purpose

The parameter test (large) is meant to provide evidence of flawless function at certain temperatures and voltages.

4.7.3.2 Test

The key parameters must be measured, and the functional behavior of the components must be measured at each of the temperatures T_{\max} , T_{RT} , and T_{\min} at voltages V_{opmin} , V_{op} , and V_{opmax} .

Internal and external measurable parameters for evaluating the components' accuracy and function must be recorded in this test.

A reference must be created, against which changes to the DUTs caused by test loads can be determined by comparison.

The recorded parameters must be documented and evaluated in the test report. This applies to the following data in particular:

- All functional variables
- Chromaticity coordinate, illumination, and contrast of light sources and displays
- Characteristic curves (sensors, converters, motors)
- Event memory entries
- Reset and error counter counts
- EEPROM content check
- Curve of the recorded current over time in the transition from "Operation_{min}" to "Operation_{max}" (with the goal of determining the aging of electric subcomponents based on current-curve changes)
- Tactile properties
- Acoustics
- Dimensional stability (deformation), gaps, function of clips
- Actuation forces/torques
- The leak tightness of leak-tight DUTs must be tested as per section 4.9.

The components must be checked in the context of a visual inspection as per DIN EN 13018. A manual shaking test must be carried out to identify any loose parts inside the device.

For components with an event memory, the content of the event memory must be read out and documented. The event memory entry must then be cleared.

The test sequence and the results must be documented.

4.7.3.3 Requirement

Functional state A

The specified tolerances of form and functional tolerances must be adhered to.

Changes in the values of the key parameters, the functional behavior, as well as irregularities in the visual inspection, must be evaluated in terms of the preceding test loads as compared to the unused condition.

The visual inspection must evaluate any external damage or changes, such as cracks, ruptures, flaking, discoloration, and deformation. Visual irregularities are not permissible.

There must not be any loose parts inside the device.

Event memory entries and counter changes must reflect precisely those that should have been triggered by the test and the functional requirement.

4.7.4 P-04 Physical analysis

4.7.4.1 Purpose

The physical analysis must be carried out after each reliability testing phase (B-sample, C-sample, etc.) to identify changes to the component as compared to the unused condition.

4.7.4.2 Test

Examination methods as per appendix H that are required for physical analysis must be agreed upon between the purchaser and contractor, and documented.

All DUTs must be opened and visually inspected as per DIN EN 13018.

If a DUT has any irregularities, the further analysis, possibly with additional DUTs or the use of additional analysis methods, must be agreed upon with the purchaser.

4.7.4.3 Requirement

The results must be documented and evaluated in the test report.

4.8 Continuous parameter monitoring with drift analysis

The key parameters to be monitored must be recorded throughout the entire test.

For components with an event memory, the event memory must be monitored continuously and the entries must be documented.

The data obtained from continuous parameter monitoring must be examined for trends and drifts to identify any component irregularities, aging, or malfunctions.

4.9 Leak tightness

4.9.1 Leak tightness requirement

The required leak tightness of a component in terms of its self-contained electronics space relative to the environment or other spaces, such as the coolant duct of a coolant circuit, is described as a leak tightness requirement. The leak tightness requirement is defined as a limit leakage rate and must be verified by means of a leak tightness test.

For the limit leakage rate in electronic control units (ECUs), an initial value of 1 to 10 cm³/min at $\Delta p = 300$ mbar can be assumed for environmental loads in the form of water. This must be adapted on a component-specific basis depending on the surrounding medium, and verified by measurements.

For components without a sealed housing, the definition and verification of a limit leakage rate is not required.

4.9.2 Leak tightness test

Adherence to the defined component-specific limit leakage rate of the electronics space of a component is verified by means of a leak tightness test.

When measuring on the DUT, the air leakage rate must be determined using common measurement methods (e.g., absolute pressure measurement, differential pressure measurement, mass airflow measurement, or volumetric flow rate measurement).

For this purpose, the component is exposed to a defined test pressure via an access point (e.g., venting element); the air leakage rate is determined by measurement after a settling period.

Because the design and application determine which pressure of a medium the component is exposed to in real-life operation, the test pressure corresponding to the most severe use case in the field must be selected. This may also be a negative pressure (vacuum). If the assumption is that the sealing system behaves differently on exposure to positive and negative pressure (e.g., sealing lips being pressed against a surface), the test must be performed with both positive and negative pressure. The test pressure to be applied must be agreed upon between the contractor and purchaser, and documented.

The leak tightness test must be performed in the context of P-03 Parameter test (large) specified in section 4.7.3 at T_{RT} . The DUT must not be exposed to any temperature fluctuations during the measurement. The measured air leakage rate must not exceed the defined, component-specific limit leakage rate, and must be documented in the test report. Changes in the air leakage rate must be evaluated and must be documented in the test report.

Part I – Electrical requirements and tests on the 12-V electric system

5 General requirements

5.1 Voltages and currents

The specified voltage curves must be interpreted as envelopes. Curves with any contour within the specified test and reference curves must be expected as the actual voltage curves.

All voltage and current specifications have reference to the component (at its terminal). This does not apply to tests for which the internal resistance R_i is specified. In this case, the voltage and current specifications refer to the source (see Figure 1).

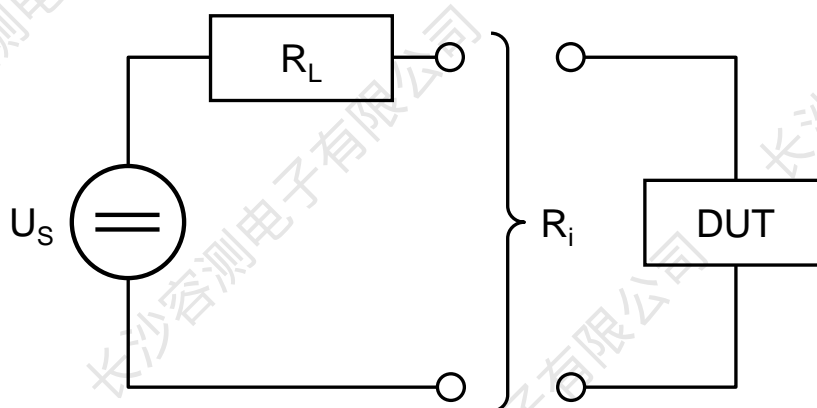

U_s	V_s
R_L	R_L
R_i	R_i
DUT	DUT

Legend

- V_s Source
- R_L Line resistance and contact resistance
- R_i Internal resistance observed at the terminals of the component in the direction of the source

Figure 1: Internal resistance

All edge descriptions refer to the 10% or 90% voltage values.

5.2 Test voltages

Test voltages, particularly those for overvoltage and undervoltage tests, may deviate significantly from the operating voltage ranges in section 5.3 and will be specified separately.

Functional state A (see section 4.2) must always be fulfilled within the voltage range applicable to the component.

5.3 Function classes and operating voltage ranges

A DUT usually has several functions, which can each be allocated to different function classes. The following table lists the functional states (A or C; see section 4.2) required for each of the function classes.

Table 13: Function classes and operating voltage ranges

Voltage range [V]	Test	Duration	Function class					
			1	2	3	4	5	6
17 – 26	E-04	≤ 60 s	C	C	C	C	C	A
16 – 17	E-01	≤ 1 h	A	A	A	C	C	A
18 – 27	E-05	≤ 300 ms	A	A	A	C	C	A
17 – 18	E-02	≤ 400 ms	A	A	A	A	A	A
16 – 17	E-02	≤ 600 ms	A	A	A	A	A	A
9.8 – 16		Static	A	A	A	A	A	A
9 – 9.8			A	A	C	A	C	C
6 – 9			A	C	C	C	C	C
≥ 9	E-03a	500 ms	A	A	A	A	A	A
≥ 7	E-11	See E-11	A	A	A	A	A	A
≥ 6	E-03b	See E-03b	A	A	A	C	C	A
≥ 4.5	E-11, normal	See E-11	A	C	C	C	C	C
≥ 3.2	E-11, severe	See E-11	A	C	C	C	C	C
≥ 0	E-10	≤ 100 μs	A	A	A	A	A	A

Minimum requirement for the use of the function classes:

Function class 1: Functions that are necessary for ensuring and maintaining the power supply or are relevant to starting

Function class 2: Functions with high availability (see Table 2)

Function class 3: Functions necessary for driving operation

Function class 4: Convenience functions that must be retained during "engine off" or "electric-system supply only from store"

Function class 5: Convenience functions that must be available during engine operation ("engine on") or "electric-system supply active"

Function class 6: Diagnostics and communication

5.4 Interface description

All interfaces must be fully described with regard to their states and electrical properties. This description is used as the basis for evaluating the test results and must be detailed accordingly.

5.5 Procedure restrictions

The test laboratory must be organized and operated as per DIN EN ISO/IEC 17025. All test equipment used for measurement must be calibrated as per DIN EN ISO/IEC 17025 (or as specified or recommended by the manufacturer), and must be traceable to PTB or an equivalent, national standards laboratory. The test devices, equipment, setups, and test methods must not limit or distort the behavior of

the DUT (e.g., current draw). They must be documented in the test report together with the accuracies and the expiration date of the calibration.

5.6 Test sequence

An electrical test begins when the DUT is completely started up and is in functional state A.

Unless otherwise specified, electrical loading must be realized and operated with original loads.

Component function according to specifications must be tested in all relevant operating phases of the device. The following operating phases must be tested:

- Startup phase/power-up
- Operation in different functional states
- Shutdown phase/power-down
- Sleep mode

Additional operating phases must be agreed upon with the purchaser.

No later than from the C-sample version, the DUT must be operated with application software during the test.

If the software package, application parameters, or processor utilization affects the test result, the affected tests must be repeated if these are changed.

The software version and level of functionality must be indicated in the test report.

The purchaser must approve the opening of DUTs, except for the physical analysis.

The electrical tests can be performed in any order. The permissible event memory entries and the functional states of the component must be specified for each test.

Unless otherwise specified in the test selection table as per section 6, all the test cases in a test must be performed.

The electrical tests may be performed during an environmental test (see part II) if this does not contradict the test requirements of the electrical test and the purchaser has approved this approach. If the DUT demonstrates any irregularities during combined tests, the tests must be repeated individually.

A set of sensitive parameters, or "key" parameters, such as the quiescent-current draw, operating currents, output voltages, contact resistances, input impedances, signal rates (rise and fall times), and bus specifications, must be defined in the Performance Specification or in agreement with the purchaser. These parameters must be checked before the start of each test, and at the conclusion of each test, in terms of their compliance with specifications.

The key parameters to be monitored must be recorded during each test. Resets of the component must be monitored in a suitable manner and documented.

Before an electrical test with a defined internal resistance, the test setup must be verified at the DUT connector by means of a reference measurement, and documented. Unless otherwise specified in the test, the reference measurement must be carried out with a dummy load equivalent to 150% of the load current for operating mode "Operation_{max}."

Before and after each test, the DUTs must undergo a P-02 Parameter test (small) as per section 4.7.2 as defined in the Performance Specification. For climatic loads, the parameter test is performed within one hour after test completion.

Before the first electrical test and after the last electrical test, the P-03 Parameter test (large) as per section 4.7.3 must be performed as defined in the Performance Specification.

The measurement results and data from the before/after tests may differ from each other only within the specified permissible tolerances. Changes in the measured values greater than the measurement accuracies must be highlighted. The measurement results must be examined for trends and drifts to detect component irregularities, aging, or malfunctions.

The physical analysis as per section 4.7.4 must be carried out after all electrical tests have been completed on at least one DUT.

6 Test selection table

Table 14: Test selection table

Test	To be applied to	To be additionally defined by the purchaser
E-01 Long-term overvoltage	Components supplied via the 12-V electric system	Component necessary for driving operation
E-02 Transient overvoltage	Components supplied via the 12-V electric system	None
E-03a Transient undervoltage	Components supplied via the 12-V electric system	None
E-03b Transient undervoltage	Components supplied via the 12-V electric system	Severity
E-04 Jump start	Components supplied via the 12-V electric system	Component relevant/not relevant to starting
E-05 Load dump	Components in vehicles with a 12-V alternator	Safety-relevant component
E-06 Ripple voltage	Test case 1 for all components, test cases 2 and 3 only for vehicles with a 12-V alternator, test case 4 only for vehicles with a DC-DC converter	Test cases based on connection in the electric system
E-07 Slow decrease and increase of the supply voltage	All components	Relevant terminal status
E-08 Slow decrease, quick increase of the supply voltage	All components	Relevant terminal status
E-09 Reset behavior	All components	Relevant terminal status, general test conditions
E-10 Brief interruptions	All components	None
E-11 Start pulses	Components supplied via the 12-V electric system; may not be applicable to vehicles without a 12-V starter	Component relevant/not relevant to starting
E-12 Voltage curve with electric system control	Components supplied via the 12-V electric system	None
E-13 Pin interruption	All components	Relevant terminal status
E-14 Connector interruption	All components	None
E-15 Reverse polarity	Components that can be exposed to reverse polarity in the vehicle	Severity, component switch-off in the event of reverse polarity
E-16 Ground potential difference	All components	None

Test	To be applied to	To be additionally defined by the purchaser
E-17 Short circuit in signal line and load circuits	All components	None
E-18 Insulation resistance	Components with galvanically isolated portions	None
E-19 Quiescent current	Components that are continuously supplied with voltage (e.g., t.30, t.30f, t.30g)	None
E-20 Dielectric strength	Components with inductive parts (e.g., motors, relays, coils)	None
E-21 Backfeeds	Components that are electrically connected to t.15 or to other terminals with a wake-up function	Severity
E-22 Overcurrents	Components that have an output	None
E-23 Equalizing currents of multiple supply voltages	Components supplied via an independent t.30	None

7 Electrical requirements and tests

7.1 E-01 Long-term overvoltage

7.1.1 Purpose

This test examines component behavior and resistance in the event of long-term overvoltage.

The overvoltage can be caused by a fault of the energy source generating the voltage and recreates a single fault in the power supply.

7.1.2 Test

Table 15: Test parameters for E-01 Long-term overvoltage

Operating mode of the DUT	Operating mode "Operation _{max} "
V_{\max}	17 V (+4%, 0%)
V_{\min}	13.5 V
t_r	< 10 ms
t_f	< 10 ms
t_1	60 min
T_{test}	$T_{\max} - 20 \text{ K}$
Number of cycles	1
Number of DUTs	At least 6

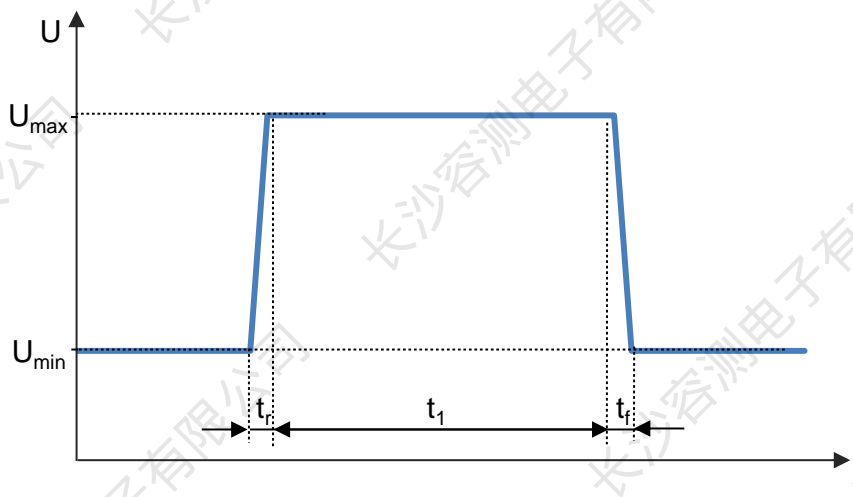

U	V
U_{\max}	V_{\max}
U_{\min}	V_{\min}

Figure 2: Test pulse for E-01 Long-term overvoltage

If no thermal steady state (< 1 K in 10 min) has been reached on the DUT after the minimum duration, the test must be prolonged until a thermal steady state is reached.

7.1.3 Requirement

See Table 13: Function classes and operating voltage ranges.

7.2 E-02 Transient overvoltage

7.2.1 Purpose

Switching off loads and engine revving (tip-in) may result in transient overvoltages in the electric system. These overvoltages are simulated in this test.

7.2.2 Test

Table 16: Test parameters for E-02 Transient overvoltage

Operating mode of the DUT	Operating mode "Driving _{max} "
V_{\min}	16 V
V_1	17 V
V_{\max}	18 V (+4%, 0%)
t_r	1 ms
t_f	1 ms
t_1	400 ms
t_2	600 ms
Number of DUTs	At least 6
Test case 1	
T_{test}	T_{\max}
Number of cycles	3
t_3	2 s
Test case 2	
T_{test}	T_{\min}
Number of cycles	3
t_3	2 s
Test case 3	
T_{test}	T_{RT}
Number of cycles	100
t_3	8 s

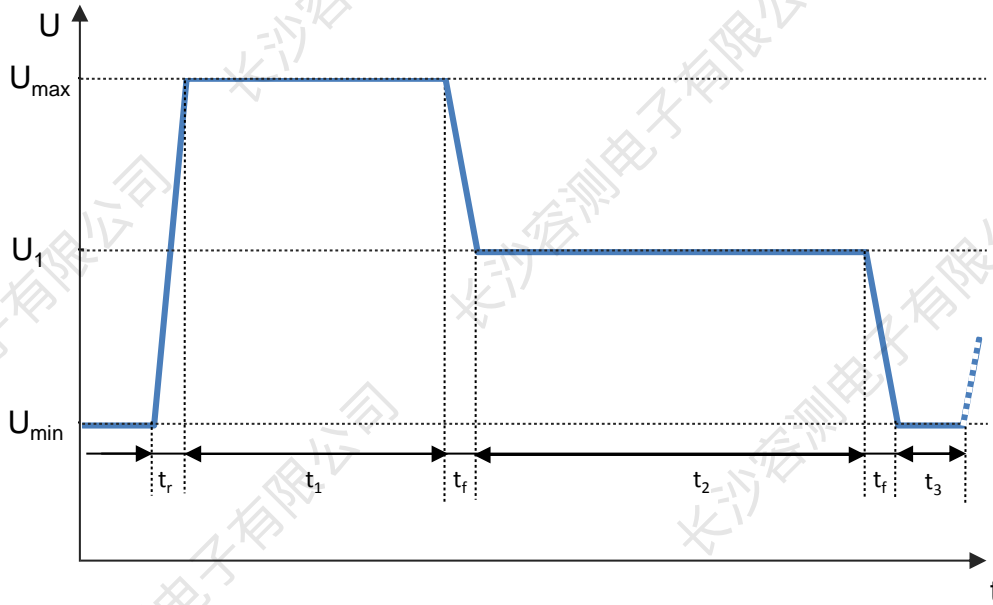

U	V
U _{max}	V _{max}
U ₁	V ₁
U _{min}	V _{min}

Figure 3: Test pulse for E-02 Transient overvoltage

7.2.3 Requirement

See Table 13: Function classes and operating voltage ranges.

7.3 E-03 Transient undervoltage

7.3.1 Purpose

Switching on loads may result in transient undervoltages, depending on the state of the power electric system (e.g., availability of energy stores).

7.3.2 Test E-03a

Table 17: Test parameters for E-03a Transient undervoltage

Operating mode of the DUT	Operating mode "Operation _{max} "
V_{max}	10.8 V
V_{min}	9 V
t_f	1.8 ms
t_1	500 ms
t_r	1.8 ms
t_2	1 s
Number of cycles	10
Test case 1	
T_{test}	T_{max}
Test case 2	
T_{test}	T_{min}

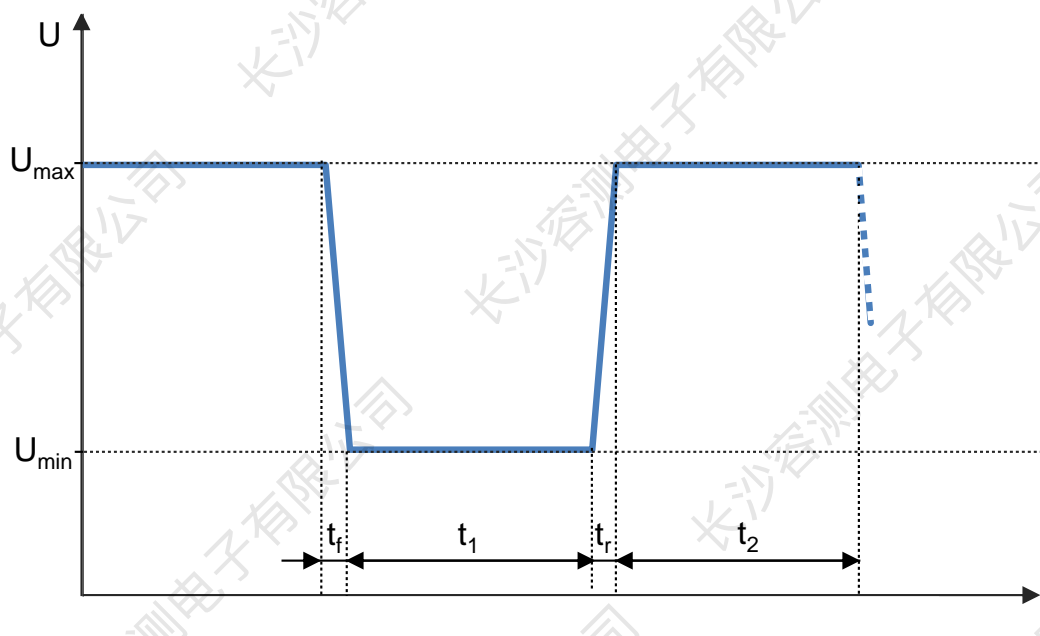

Figure 4: Test pulse for E-03a Transient undervoltage

U	V
U_{max}	V_{max}
U_{min}	V_{min}

7.3.3 Test E-03b

Table 18: Test parameters for E-03b Transient undervoltage

Parameter	Severity 1
Operating mode of the DUT	Operating mode "Operation _{max} "
V ₁	10.8 V
V ₂	6 V
V ₃	8 V
V ₄	9 V
t ₁	5 ms
t ₂	20 ms
t ₃	2 ms
t ₄	180 ms
t ₅	1 ms
t ₆	300 ms
t ₇	2 ms
t ₈	1 s
Number of cycles	10
Test case 1	
T _{test}	T _{max}
Test case 2	
T _{test}	T _{min}

Severity 1 must be applied for functions that are used to maintain driving readiness and for the power supply, as well as functions for which a higher degree of availability is required.

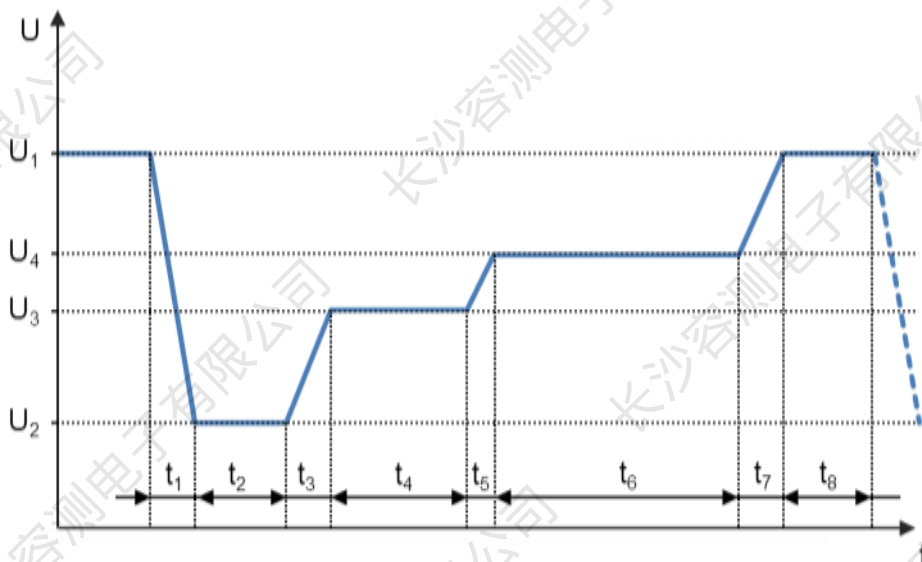

Figure 5: Test pulse for E-03b Transient undervoltage

U	V
U ₁	V ₁
U ₂	V ₂
U ₃	V ₃
U ₄	V ₄

7.3.4 Requirement

See Table 13: Function classes and operating voltage ranges.

7.4 E-04 Jump start

7.4.1 Purpose

This test simulates an external power supply to a vehicle. The maximum test voltage is yielded from commercial vehicle systems and their increased electric-system voltages.

7.4.2 Test

Table 19: Test parameters for E-04 Jump start

Operating mode of the DUT	Operating mode "Operation _{max} "
V_0	0 V
V_1	3 V (+0%, -15%)
V_2	10.8 V
V_3	26 V (+4%, 0%)
t_1	1 s
t_2	0.5 s
t_3	5 s
t_4	1 s
t_5	60 s
t_r	< 2 ms
t_f	< 100 ms
Number of cycles	1
Number of DUTs	At least 6

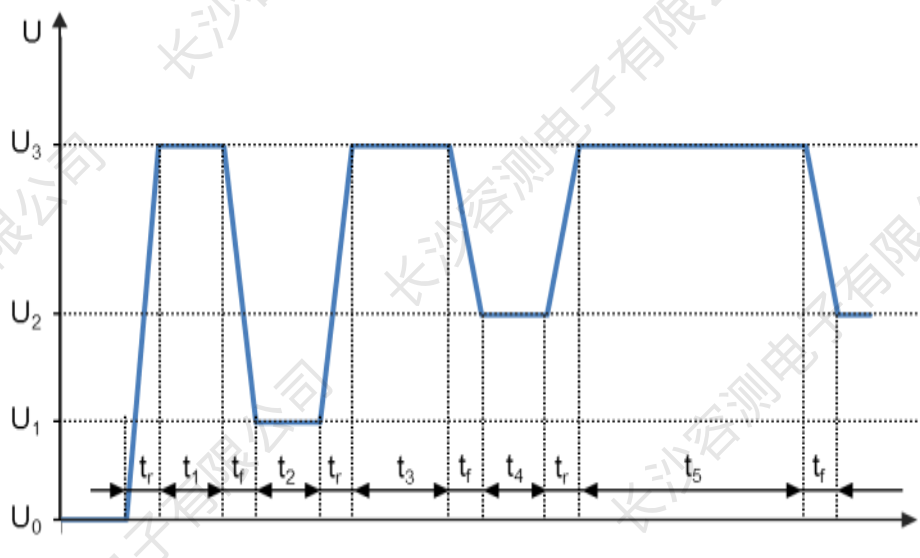

Figure 6: Test pulse for E-04 Jump start

U	V
U_1	V_1
U_2	V_2
U_3	V_3
U_0	V_0

7.4.3 Requirement

See Table 13: Function classes and operating voltage ranges.

7.5 E-05 Load dump

7.5.1 Purpose

Dumping of an electric load, in conjunction with a battery with reduced buffering capacity, results in a high-energy overvoltage pulse due to generator properties. This test is meant to simulate this pulse.

7.5.2 Test

Table 20: Test parameters for E-05 Load dump

Operating mode of the DUT	Operating mode "Driving _{max} "
V_{\min}	13.5 V
V_{\max}	27 V (+4%, 0%)
t_r	≤ 2 ms
t_1	300 ms
t_f	≤ 30 ms
Break between cycles	1 min
Number of cycles	10
Number of DUTs	At least 6

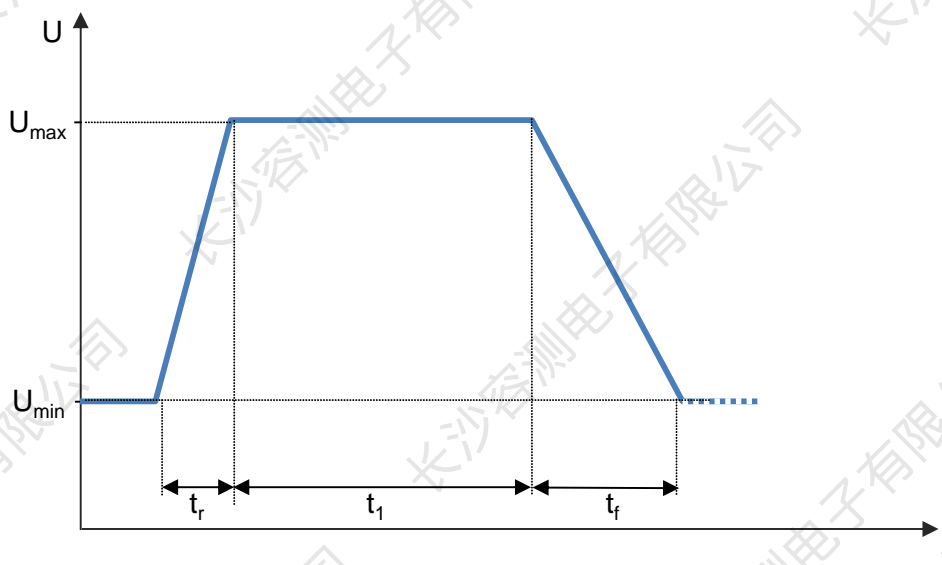

Figure 7: Test pulse for E-05 Load dump

U	V
U_{\max}	V_{\max}
U_{\min}	V_{\min}

7.5.3 Requirement

See Table 13: Function classes and operating voltage ranges.

7.6 E-06 Ripple voltage

7.6.1 Purpose

Alternating-current (AC) voltages may be superimposed on the electric system. This ripple voltage may be present at any time during engine operation. These tests simulate this situation.

7.6.2 Test

Table 21: Test parameters for E-06 Ripple voltage

Operating mode of the DUT	Operating mode "Driving _{max} "
V_{max}	V_{opmax}
R_i	$\leq 100 \text{ m}\Omega$
Type of wobble	Triangle, logarithmic
Number of cycles	15
Number of DUTs	At least 6
Test case 1	
V_{PP}	2 V (+4%, 0%)
Frequency range	15 Hz to 30 kHz
Wobble period t_1	2 min
Test case 2	
V_{PP}	3 V (+4%, 0%) for components between the battery and generator, particularly in the case of a battery connection far from the generator
Frequency range	15 Hz to 30 kHz
Wobble period t_1	2 min
Test case 3	
V_{PP}	6 V (+4%, 0%) for all components during drives without the battery (emergency mode) or in the case of a connection close to the generator
Frequency range	15 Hz to 30 kHz
Wobble period t_1	2 min
Test case 4	
V_{PP}	1 V (+4%, 0%) for components supplied from the DC-DC converter
Frequency range	30 kHz – 200 kHz
Wobble period t_1	10 min

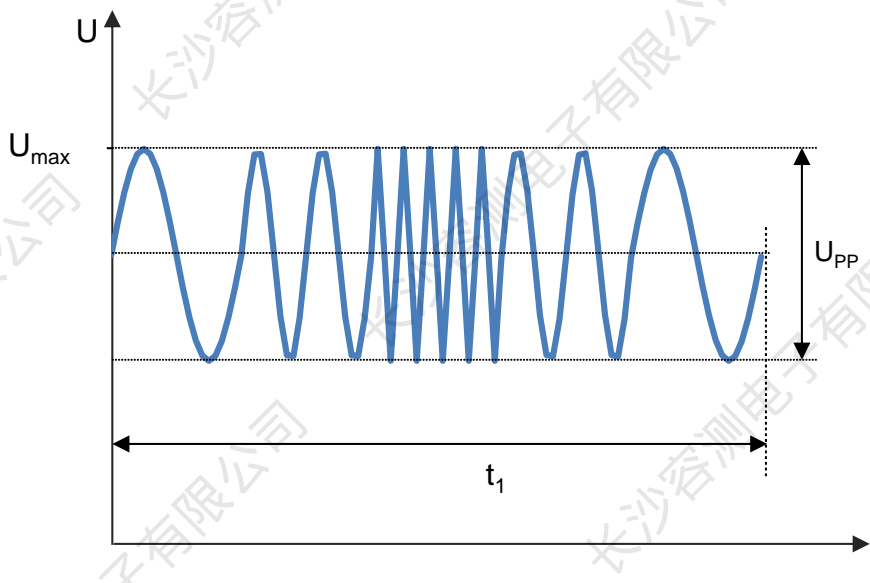

Figure 8: Test pulse for E-06 Ripple voltage

U	V
U_{max}	V_{max}
U_{PP}	V_{PP}

7.6.2.1 Test setup

The electric system conditions must be agreed upon with the appropriate departments. The test setup must be documented in detail, including line inductance values, line capacitance values, and line resistance values.

7.6.3 Requirement

Test case 1: functional state A

Test case 2: functional state A

Test case 3:

a) Components necessary for driving operation:

Functional state A

b) All other components:

Functional state C

Test case 4: functional state A

7.7 E-07 Slow decrease and increase of the supply voltage

7.7.1 Purpose

The slow decrease and increase of the supply voltage is simulated as it occurs during the slow discharging and charging processes of the vehicle battery.

7.7.2 Test E-07a

Table 22: Test parameters for E-07a Slow decrease and increase of the supply voltage

Operating mode of the DUT	Operating mode "Operation _{min} " and "Operation _{max} " Must be performed with all relevant states of the voltage supply terminals (e.g., t.15, t.30, t.87) and their combinations
Start voltage	V _{opmax} (+4%, 0%)
Rate of voltage change	0.5 V/min (+10%, -10%)
V ₁	V _{opmin}
t ₁	Hold time at V ₁ until event memory has been completely read out
Minimum voltage	0 V
V ₂	V _{opmin}
t ₂	Hold time at V ₂ until event memory has been completely read out
End voltage	V _{opmax} (+4%, 0%)
Number of cycles	For each relevant terminal state and their combinations: 1 cycle with operating mode "Operation _{min} " 1 cycle with operating mode "Operation _{max} "
Number of DUTs	3

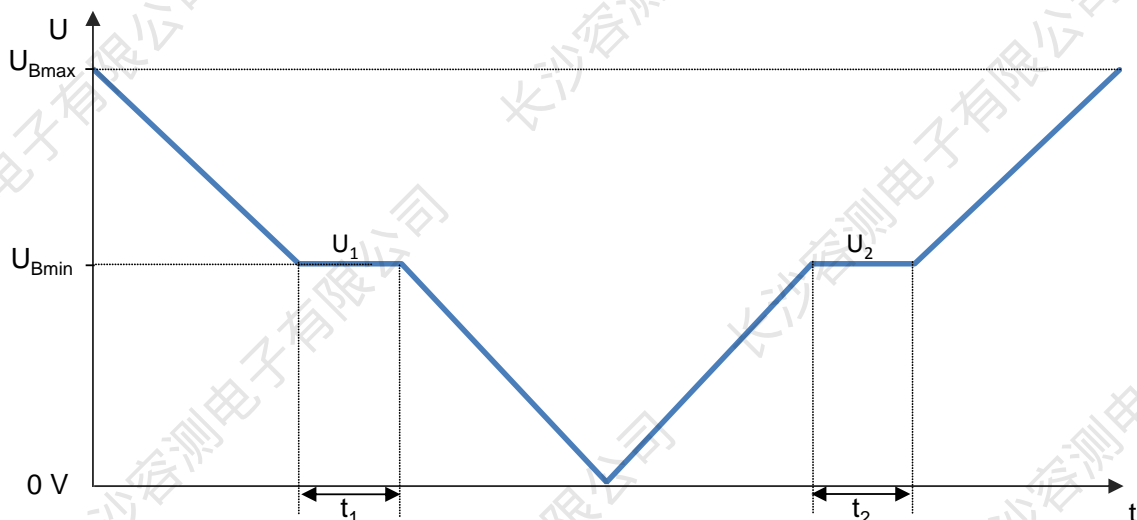

Figure 9: Test pulse for E-07a Slow decrease and increase of the supply voltage

U	V
U _{Bmax}	V _{opmax}
U _{Bmin}	V _{opmin}
U ₁	V ₁

U_2	V_2
-------	-------

7.7.3 Test E-07b

Table 23: Test parameters for E-07b Slow decrease and increase of the supply voltage

Operating mode of the DUT	Operating mode "Operation _{min} " and "Operation _{max} " Must be performed with all relevant states of the voltage supply terminals (e.g., t.15, t.30, t.87) and their combinations
V_{max}	14.5 V
V_{min}	1.5 V
V_{PP}	3 V
V_1	$V_{opmin} + 1.5 V$
V_2	$V_{opmin} + 1.5 V$
Frequency	Sinusoidal, 50 Hz
Wobble period	52 min
Number of cycles	For each relevant terminal state and their combinations: 1 cycle with operating mode "Operation _{min} " 1 cycle with operating mode "Operation _{max} "
Number of DUTs	3

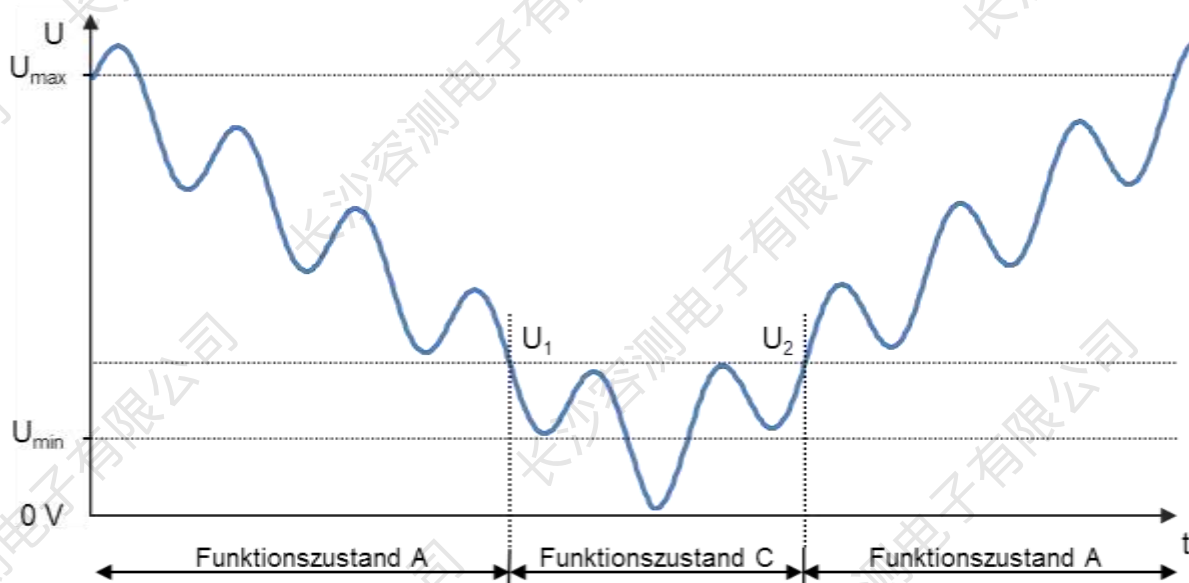

Figure 10: Test pulse for E-07b Slow decrease and increase of the supply voltage

U	V
U_{max}	V_{max}
U_{min}	V_{min}
U_1	V_1
U_2	V_2
Funktionszustand A	Functional state A
Funktionszustand C	Functional state C

7.7.4 Requirement

The evaluation of the test results depends on the voltage range that is applied to the component during the test.

A distinction is made between the following:

- a) Within the defined operating voltage range of the component:
Functional state A
- b) Outside of the defined operating voltage range of the component:
Functional state C

7.8 E-08 Slow decrease, quick increase of the supply voltage

7.8.1 Purpose

This test simulates the slow decrease of the battery voltage to 0 V and the sudden re-application of the battery voltage, e.g., from a jump start source.

7.8.2 Test

Table 24: Test parameters for E-08 Slow decrease, quick increase of the supply voltage

Operating mode of the DUT	Operating mode "Operation _{min} " and "Operation _{max} " Must be performed with all relevant states of the voltage supply terminals (e.g., t.15, t.30, t.87) and their combinations
Start voltage	V_{opmax} (+4%, 0%)
Voltage drop	0.5 V/min (+10%, -10%)
V_1	V_{opmin}
t_1	Hold time at V_1 until event memory has been completely read out
Hold time at V_{opmin}	Until the event memory has been completely read out
Minimum voltage	0 V
t_2	At least 1 min, but until internal capacitors are fully discharged
End voltage	V_{opmax} (+4%, 0%)
t_r	≤ 0.5 s
Number of cycles	For each relevant terminal state and their combinations: 1 cycle with operating mode "Operation _{min} " 1 cycle with operating mode "Operation _{max} "
Number of DUTs	At least 6

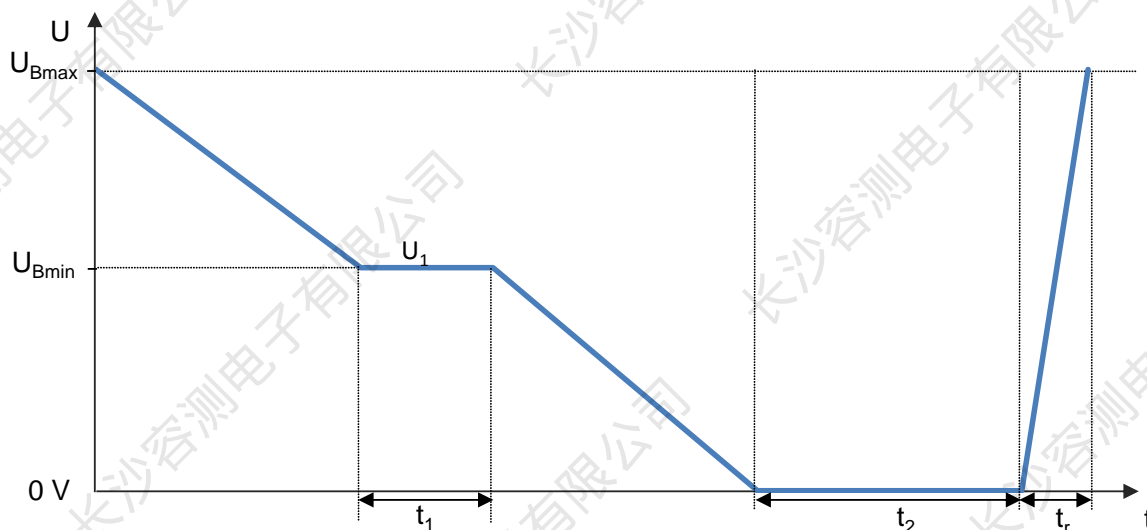

Figure 11: Test pulse for E-08 Slow decrease, quick increase of the supply voltage

U	V
U_{Bmax}	V_{opmax}

U_{Bmin}	V_{opmin}
U_1	V_1

7.8.3 Requirement

The evaluation of the test results depends on the voltage range that is applied to the component during the test.

A distinction is made between the following ranges:

- a) Within the defined operating voltage range of the component:
Functional state A
- b) Outside of the defined operating voltage range of the component:
Functional state C

7.9 E-09 Reset behavior

7.9.1 Purpose

The reset behavior of a component in its environment is recreated and tested. General test conditions (e.g., network, terminal, system) must be described in detail.

An arbitrary chronological sequence of repeated switch-on/switch-off processes occurs during operation and must not result in undefined component behavior.

The reset behavior is reflected in a voltage variance and in a time-based variance. Two different test sequences are required to simulate varying switch-off times. A component must always run through both sequences.

7.9.2 Test

Table 25: Test parameters for E-09 Reset behavior

Operating mode of the DUT	Operating mode "Operation _{min} ," "Driving _{min} ," and "Operation _{max} " Must be performed with all relevant states of the voltage supply terminals (e.g., t.15, t.30, t.87) and their combinations
V _{max}	V _{opmin} (0%, -4%)
V _{th}	6 V
ΔV ₁ (range V _{max} to V _{th})	0.5 V
ΔV ₂ (range V _{th} to 0 V)	0.2 V
t ₂	At least 10 s and until the DUT has reached 100% operability again (all systems rebooted without errors).
t _r	≤ 10 ms
t _f	≤ 10 ms
Number of cycles	For each test sequence, for each relevant terminal state and their combinations: 1 cycle with operating mode "Operation _{min} " 1 cycle with operating mode "Driving _{min} " 1 cycle with operating mode "Operation _{max} "
Number of DUTs	At least 3
Test case 1	
t ₁	5 s
Test case 2	
t ₁	100 ms

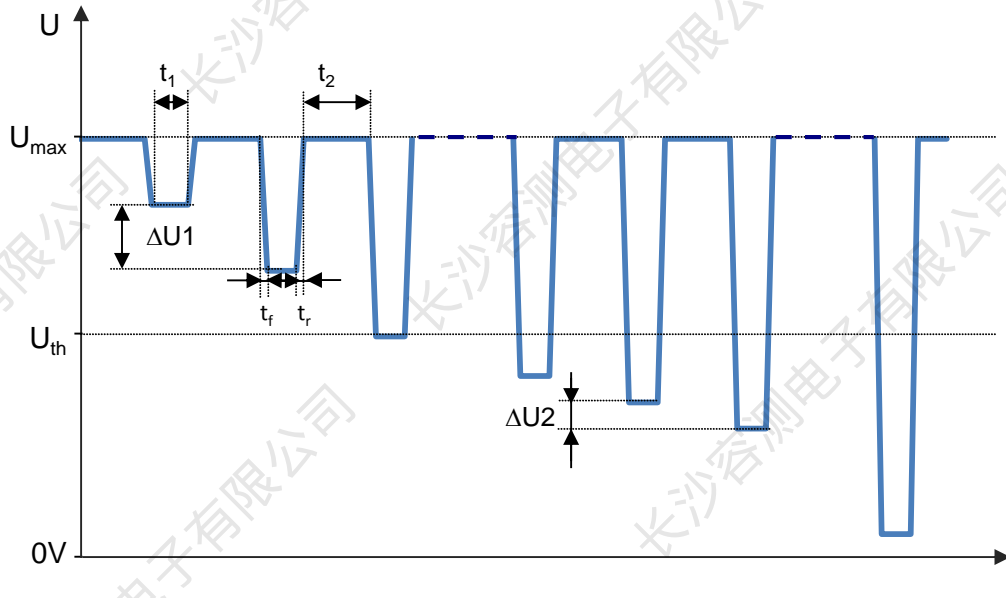

Figure 12: Test pulse for E-09 Reset behavior

U	V
U_{max}	V_{max}
U_{th}	V_{th}
ΔU_1	ΔV_1
ΔU_2	ΔV_2
t	t

7.9.3 Requirement

Functional state A once V_{max} is reached again

Undefined operating states must not occur under any circumstances.

Proof of adherence to the specified threshold value must be provided. The voltage level above which the component leaves functional state A for the first time must be recorded.

7.10 E-10 Brief interruptions

7.10.1 Purpose

This test simulates the behavior of the component in the event of brief interruptions of varying durations.

Test case 1 represents a supply voltage interruption at the component.

Test case 2 represents a supply voltage interruption in the electric system.

Such interruptions can occur due to events such as contact faults and line faults or relay-contact bounce.

7.10.2 Test

Table 26: Test parameters for E-10 Brief interruptions

Operating mode of the DUT	Operating mode "Operation _{max} "	
V_{test}	11 V	
State 1 (Z1)	Switch 1 (S1) closed	
Z2	S1 open	
t_r	$\leq (0.1 * t_1)$	
t_f	$\leq (0.1 * t_1)$	
Switch S1 must be switched with the following sequences:	t_1	Increments
Severity 1	10 μ s to 100 μ s	10 μ s
	100 μ s to 1 ms	100 μ s
	1 ms to 10 ms	1 ms
	10 ms to 100 ms	10 ms
	100 ms to 2 s	100 ms
Severity 2	10 μ s to 100 μ s	10 μ s
	100 μ s to 1 ms	100 μ s
	1 ms to 200 ms	1 ms
	200 ms to 2 s	100 ms
t_2	> 10 s Test voltage V_{test} must be held at least until the DUT and the peripherals have reached 100% operability again.	
Number of cycles	1	
Number of DUTs	At least 6	
Test case 1	S1 switched, S2 statically open	
Test case 2	S1 switched, S2 negated with respect to S1	

The duration of the voltage sag is increased by the increments specified in Table 26. This yields the diagram shown in Figure 13.

The voltage on the DUT can be limited by the test setup to the maximum voltage of test E-05 Load dump (see section 7.5).

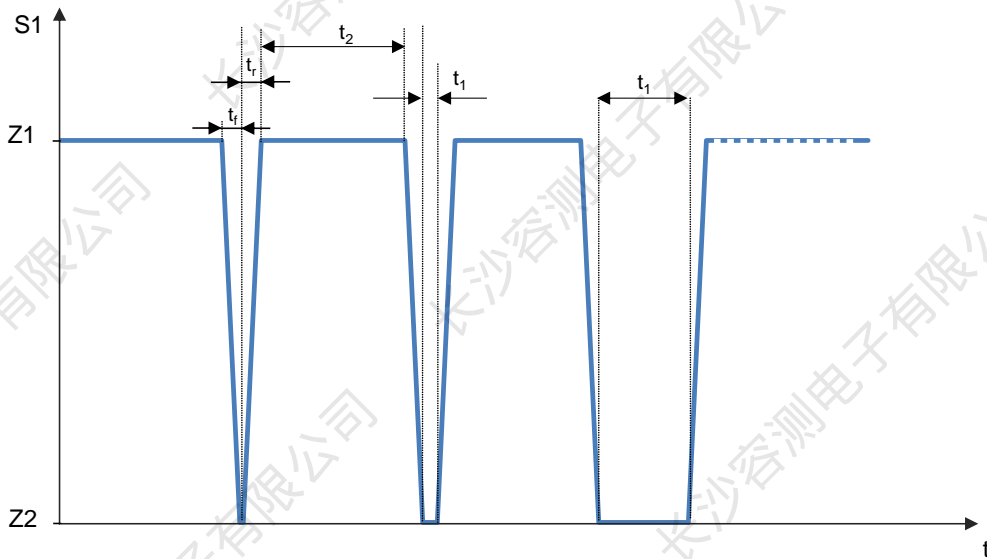

Figure 13: Change in state of switch S1 for E-10 Brief interruptions

7.10.2.1 Test setup

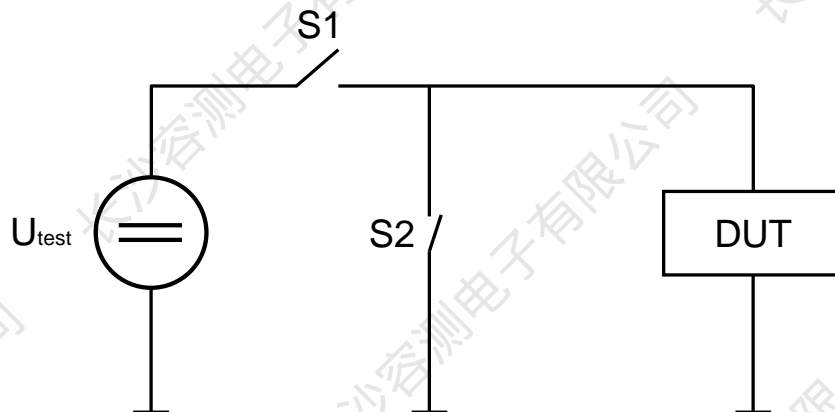

Figure 14: Schematic circuit diagram for E-10 Brief interruptions

The closed switch S2, including the necessary cables, must be implemented with a series resistance of $< 100 \text{ m}\Omega$.

7.10.2.2 Test sequence

One reference measurement each with $100 \text{ }\Omega$ ($\pm 5\%$) and $1 \text{ }\Omega$ ($\pm 5\%$) as a DUT dummy must be carried out and documented. The slew rate must be verified with this test setup. Low-inductance components must be used as resistors. The tests as per Table 26 must then be performed.

7.10.3 Requirement

For $t_1 < 100 \text{ }\mu\text{s}$: functional state A

For $t_1 \geq 100 \mu\text{s}$: functional state C

The time value t_1 beyond which the DUT leaves functional state A for the first time must be recorded.

7.11 E-11 Start pulses

7.11.1 Purpose

When the engine is started, the battery voltage drops to a low value for a short period in order to then rise again slightly. Most components are briefly activated immediately before the starting process, deactivated during the starting process, and then activated again after the starting process once the engine is running. This test examines the behavior of the component in the event of voltage sags caused by starting.

The starting process may be carried out under varying vehicle starting conditions: cold start and hot start (automatic restart in the case of a start-stop system). In order to cover both cases, two different test cases are required. A component must always run through both sequences.

7.11.2 Test

Table 27: Test parameters for E-11 Start pulses

Operating mode of the DUT	Operating mode "Operation _{min} ," "Driving _{min} ," and "Operation _{max} " If necessary, additional operating loads must be defined in the respective operating mode.
Test pulse	- Cold start: "normal" and "severe" test pulse as per Table 28 - Hot start: "short" and "long" test sequence as per Table 29
Number of DUTs	At least 6

7.11.2.1 Test case 1 – Cold start

Table 28: Test parameters for E-11 Cold start

Parameter	"Normal" test pulse	"Severe" test pulse
V _{op}	11.0 V	11.0 V
V _T	4.5 V (0%, -4%)	3.2 V ^{+0.2 V}
V _S	4.5 V (0%, -4%)	5.0 V (0%, -4%)
V _A	6.5 V (0%, -4%)	6.0 V (0%, -4%)
V _R	2 V	2 V
t _f	≤ 1 ms	≤ 1 ms
t ₄	0 ms	19 ms
t ₅	0 ms	≤ 1 ms
t ₆	19 ms	329 ms
t ₇	50 ms	50 ms
t ₈	10 s	10 s
t _r	100 ms	100 ms
f	2 Hz	2 Hz
Break between cycles	2 s	2 s
Test cycles	10	10

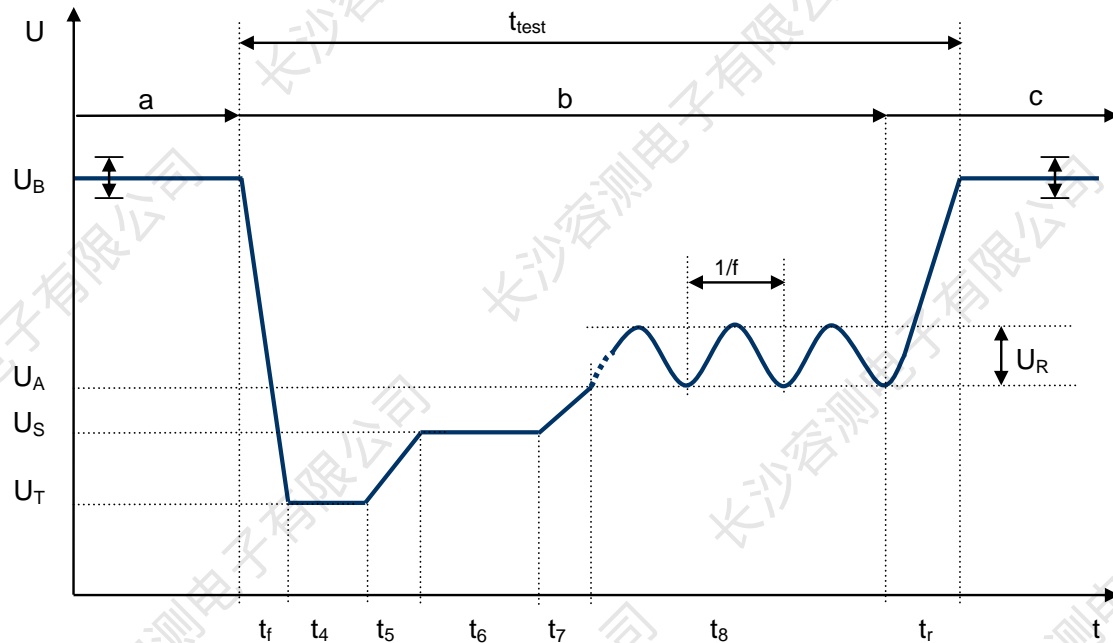

U	V
U _B	V _{op}
U _A	V _A
U _S	V _S
U _T	V _T
U _R	V _R

Legend

- a t.50 off
- b t.50 on
- c t.50 off
- t_{test} Cycle

Figure 15: Test pulse for E-11 Cold start

7.11.2.2 Test case 2 – Hot start

Table 29: Test parameters for E-11 Hot start

Parameter	"Short" test sequence	"Long" test sequence
V _{op}		11.0 V
V _T		7.0 V (0%, -4%)
V _S		8.0 V (0%, -4%)
V _A		9.0 V (0%, -4%)
t ₅₀		≥ 10 ms
t _f		≤ 1 ms
t ₄		15 ms
t ₅		70 ms
t ₆		240 ms
t ₇		70 ms
t ₈		600 ms
t _r		≤ 1 ms
Break between cycles	5 s	20 s
Test cycles	10	100

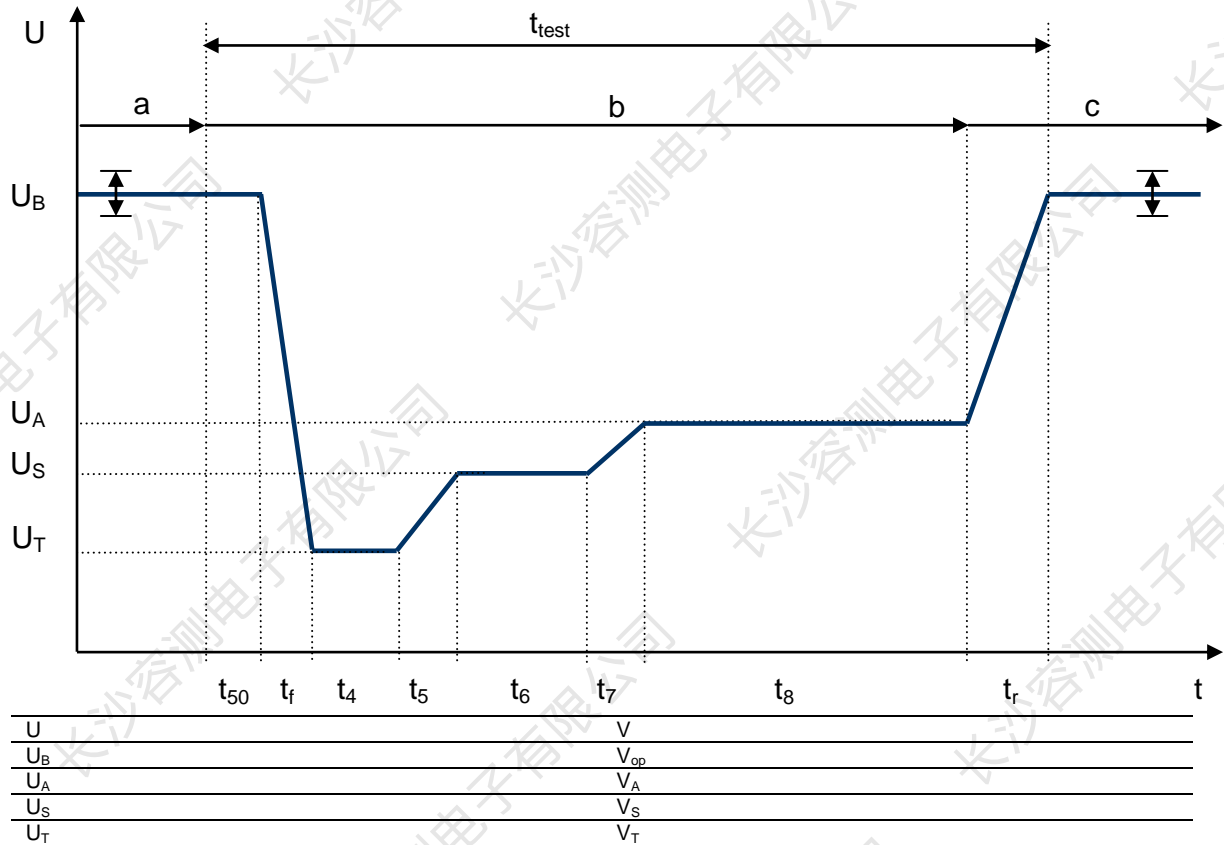

Legend

- a t.50 off
- b t.50 on
- c t.50 off
- t_{test} Cycle

Figure 16: Test pulse for E-11 Hot start

7.11.3 Requirement

The test must not result in any event memory entries.
The vehicle must be capable of starting in all cases.

7.11.3.1 Components relevant to starting:

Test case 1 – Cold start:

- "Normal" test pulse: functional state A
- "Severe" test pulse: functional state A

Test case 2 – Hot start:

- "Long" test sequence: functional state A
- "Short" test sequence: functional state A

7.11.3.2 Components not relevant to starting:

Test case 1 – Cold start:

- "Normal" test pulse: functional state C

"Severe" test pulse: functional state C

Test case 2 – Hot start:

"Long" test sequence: functional state A

"Short" test sequence: functional state A

7.12 E-12 Voltage curve with electric system control

7.12.1 Purpose

This test simulates the behavior of the electric system with voltage controls, e.g., with the use of intelligent generator or DC-DC converter controls. By means of the control, voltage curves can be set in the range between constant voltage to permanent voltage fluctuations according to the test cases. This is relevant to all load cases that the component can assume with the engine running or the vehicle ready for operation.

7.12.2 Test

Table 30: Test parameters for E-12 Voltage curve with electric system control

Operating mode of the DUT	Operating mode "Driving _{max} "
V_{\min}	(11.8 V - ΔV) (0%, -4%)
V_{\max}	(16 V - ΔV) (+4%, 0%)
t_1	2 s
t_r	400 ms
t_f	400 ms
Number of cycles	10
Number of DUTs	At least 6
Test case 1	
ΔV	0 V
Test case 2	
ΔV	0.7 V
Test case 3	
ΔV	2 V

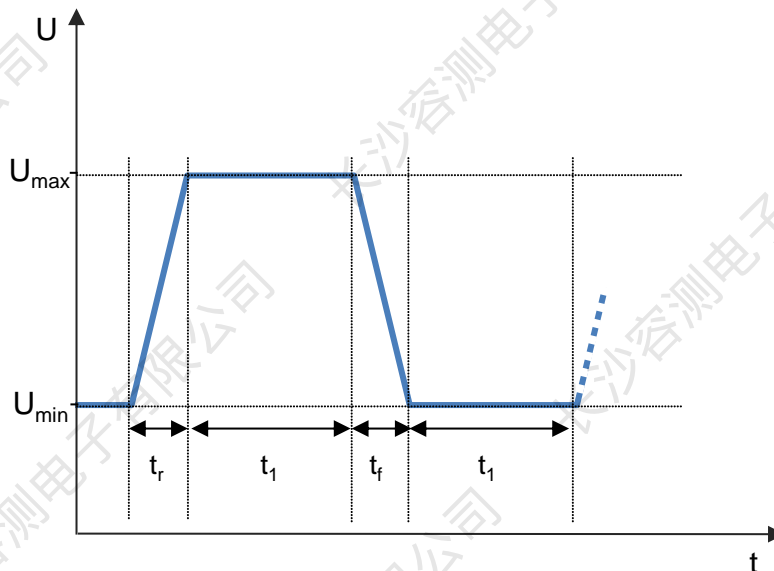

Figure 17: Test pulse for E-12 Voltage curve with electric system control

U	V
U_{\max}	V_{\max}
U_{\min}	V_{\min}

7.12.3 Requirement

Functional state A

7.13 E-13 Pin interruption

7.13.1 Purpose

This test simulates the line interruption of individual pins. The test must be performed in two different operating states. Different pulse forms must be used, because the possible interruptions may differ greatly in terms of their duration (from loose contacts to permanent interruption).

7.13.2 Test

Table 31: Test parameters for E-13 Pin interruption

Operating mode of the DUT	Operating mode "Operation _{min} " and "Operation _{max} " Must be performed with all relevant states of the voltage supply terminals (e.g., t.15, t.30, t.87) and their combinations
Z1	State 1: pin connected
Z2	State 2: pin interrupted
t _r	≤ (0.1 * t ₁)
t _f	≤ (0.1 * t ₁)
Number of cycles	The following applies to the two test cases and the relevant terminal state: 3 cycles with operating mode "Operation _{min} " 3 cycles with operating mode "Operation _{max} " Each test must be evaluated separately.
Number of DUTs	At least 6
Test case 1	
	Each pin must be removed for t = 10 s and then replaced (slow interval).
Test case 2	
	Burst on each pin to simulate a loose contact (figure 18)
Number of pulses t ₂ in the burst	4 000
a	Burst
t ₁	0.1 ms
t ₂	1 ms
t ₃	10 s

7.14 E-14 Connector interruption

7.14.1 Purpose

This test simulates the line interruption of connectors.

7.14.2 Test

Table 32: Test parameters for E-14 Connector interruption

Operating mode of the DUT	Operating mode "Operation _{min} " and "Operation _{max} "
Number of cycles	Each connector must be removed once in both operating modes.
Number of DUTs	At least 6

7.14.2.1 Test sequence

Each connector must be removed from the DUT for 10 s and then replaced. If the DUT has several connectors, each connector must be tested individually. The test sequence must be varied. If there are several connectors, their combinations must also be tested.

7.14.3 Requirement

Functional state C

7.15 E-15 Reverse polarity

7.15.1 Purpose

The resistance of the DUT to reverse-polarity battery connection during jump starting is tested. Reverse polarity can occur several times and must not cause damage to the component. Reverse polarity protection must be ensured for any voltages down to the minimum test voltage. The vehicle fuse is not part of the reverse polarity protection strategy.

7.15.2 Test

All relevant connections of the original circuitry must be tested. The DUT must be activated according to the circuitry in the vehicle. The test must be performed at various voltages between 0 V and the maximum values specified in Table 33.

The current draw during the test must be documented.

Table 33: Test parameters for E-15 Reverse polarity

Operating mode of the DUT	Operating mode "Operation _{min} " (static reverse polarity) Operating mode "Operation _{max} " (dynamic reverse polarity)
Test case 1	Static reverse polarity as per Table 34
Test case 2	Dynamic reverse polarity as per Table 35
Number of DUTs	At least 6

7.15.2.1 Test case 1 – Static reverse polarity

This test case checks the robustness of the component at various reverse polarity voltages that can arise depending on the vehicle state.

Table 34: Test parameters for E-15 Static reverse polarity

V_{max}	0 V
V_{min}	-14.0 V
ΔV_1	-1 V
Severity 1	$R_i < 100 \text{ m}\Omega$
Severity 2	$R_i < 30 \text{ m}\Omega$
t_1	60 s For a component for which the operating voltage is switched off by a relay in the event of reverse polarity, the following deviating value applies: 8 ms
t_2	$\geq 60 \text{ s}$, but at least until the component has reached the same thermal state as at the start of the test
t_r	$\leq 10 \text{ ms}$
t_f	$\leq 10 \text{ ms}$
Number of cycles	1

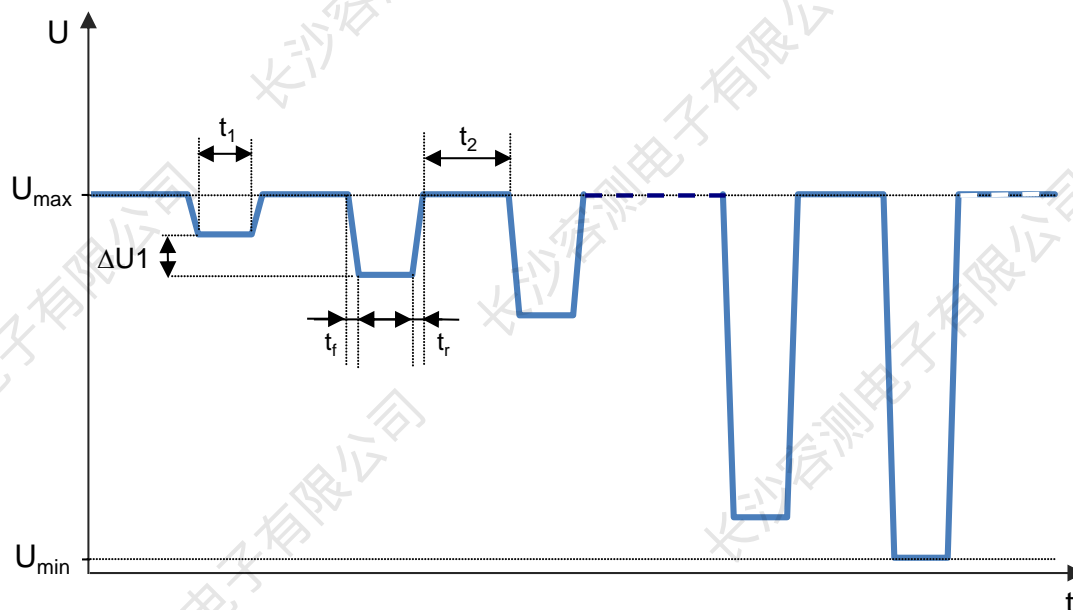

Figure 19: Test pulse for E-15 Static reverse polarity

U	V
U _{max}	V _{max}
U _{min}	V _{min}
ΔU1	ΔV1

7.15.2.2 Test case 2 – Dynamic reverse polarity

This test case checks the reverse polarity of the component during operation in a vehicle that is no longer capable of starting.

Table 35: Test parameters for E-15 Dynamic reverse polarity

V _{max}	10.8 V
V _{min}	-4.0 V
Severity 1	R _i < 100 mΩ
Severity 2	R _i < 30 mΩ
t ₁	60 s For a component for which the operating voltage is switched off by a relay in the event of reverse polarity, the following deviating value applies: 8 ms
t ₂	≤ 5 min
t _r	≤ 10 ms
t _f	≤ 10 ms
Number of cycles	3

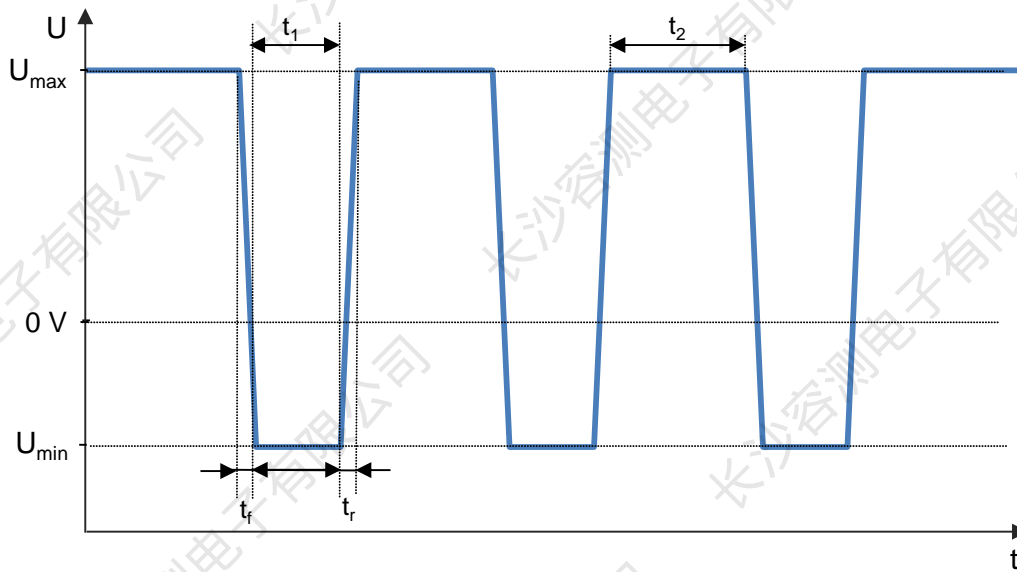

Figure 20: Test case for E-15 Dynamic reverse polarity

U	V
U_{max}	V_{max}
U_{min}	V_{min}
$\Delta U1$	$\Delta V1$

7.15.3 Requirement

Safety-relevant functions, e.g., of power windows, the power sliding sunroof, or the starter, must not be triggered during periods of reverse polarity.

Functional state C

7.16 E-16 Ground potential difference

7.16.1 Purpose

Potential differences between various ground connection locations can cause signal distortions between components at these connection locations. It must be ensured that potential differences between ground points up to a magnitude of ± 1 V (static) in the electrical assembly do not affect component functions.

7.16.2 Test

If the DUT has several voltage and ground connections, the test must be performed separately for each connection point.

The component is wired up as in Figure 21.

Table 36: Test parameters for E-16 Ground potential difference

Operating mode of the DUT	Operating mode "Operation _{max} "
Test duration	≥ 60 s
V	1 V
Number of cycles	Both switching positions
Number of DUTs	At least 6

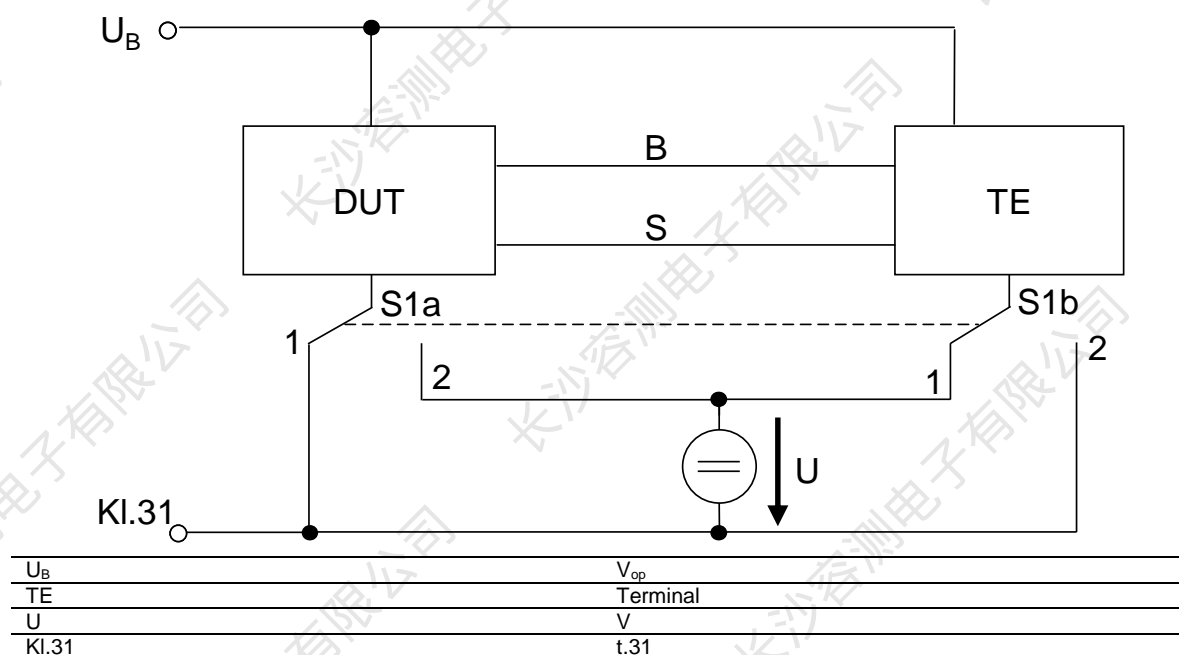

Legend

- B Bus system
- S Signal line
- S1 Two-pin (a/b) change-over switch
- Terminal Other component, e.g., test reference, test bed, simulation control module, actuator, sensor, or load

Figure 21: Schematic circuit diagram for E-16 Ground potential difference

7.16.3 Requirement

Functional state A

7.17 E-17 Short circuit in signal line and load circuits

7.17.1 Purpose

This test simulates short circuits on all device inputs and outputs and in the load circuit. All inputs and outputs must be short-circuit-proof to t.30 and t.31 (for activated and non-activated outputs, with and without voltage supply, and with and without ground connection).

The component must be able to withstand a sustained short circuit.

7.17.2 Test

Table 37: Test parameters for E-17 Short circuit in signal line and load circuits

Operating mode of the DUT	Operating mode "Operation _{max} "
Test duration	Each combination of test voltage and test case for 60 s
Test voltages	V_{opmin} and V_{opmax}
Test case 1	Each pin alternately to t.30 and t.31 with voltage supply and with ground connection
Test case 2	Each pin alternately to t.30 and t.31 without voltage supply and with ground connection
Test case 3	Each pin alternately to t.30 and t.31 with voltage supply and without ground connection
Number of DUTs	At least 6

If the voltage supply/ground supply is fed via several pins, these combinations must also be taken into account.

7.17.2.1 Test setup

The power supply unit used for the test must be able to supply the short-circuit currents to be expected by the component. If this is not possible, buffering of the power supply unit by means of a car battery is permissible (V_{opmax} is the maximum charging voltage in this case).

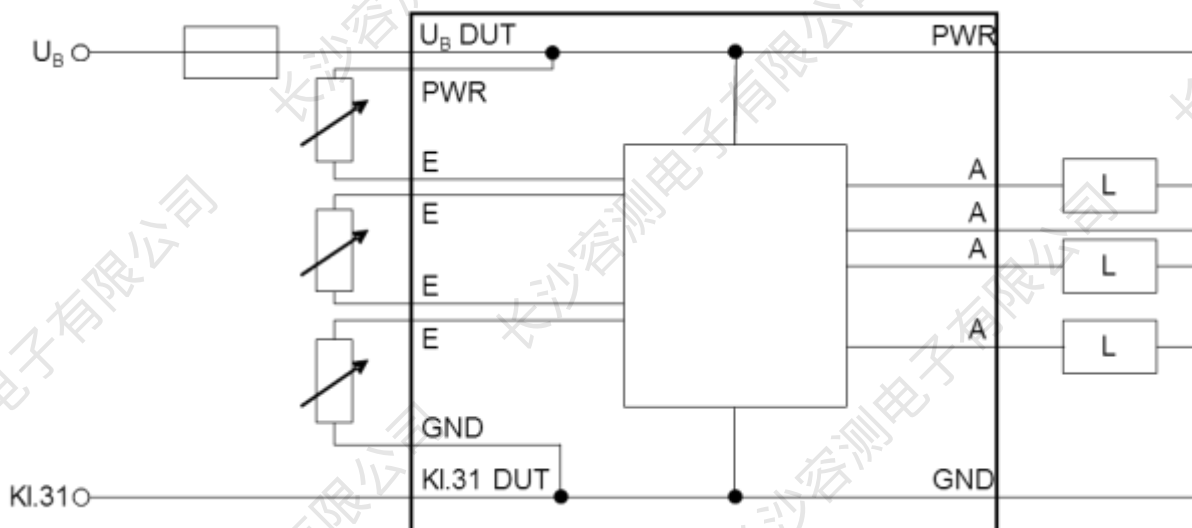

Figure 22: Schematic circuit diagram

U_B	V_{op}
U_B DTU	DUT V_{op}
PWR	PWR
E	I
GND	GND
KI. 31 DUT	DUT t.31
A	O
L	L
KI. 31	t.31

Legend

L	Load
I	Input
O	Output
PWR	Output of DUT V_{op}
GND	Input/output of DUT t.31

7.17.2.2 Test sequence

For inputs and outputs: record and evaluate the curve of the short-circuit current over time.

The functional effects of the short circuits must be documented.

7.17.3 Requirement

For inputs and outputs (I and O): functional state C

For looped-through supply voltages (PWR): functional state D2

For device ground (GND): functional state E. This also applies to the vehicle contact set and wiring harness, and must be guaranteed by the component.

7.18 E-18 Insulation resistance

7.18.1 Purpose

This test determines the insulation resistance between components with galvanic isolation. Only the galvanically isolated pins that are connected in the vehicle and that require isolation properties for their function are examined.

7.18.2 Test

Table 38: Test parameters for E-18 Insulation resistance

Operating mode of the DUT	Operating mode "Assembly _{not installed} "
Test voltage	500 V DC
Test duration	60 s
Test points	Application of the test voltage <ul style="list-style-type: none"> - To terminals without a galvanic connection - Between connection pins and conductive housing without a galvanic connection - Between connection pins and an electrode around the housing if the housing is non-conductive - To additional test points agreed upon with the appropriate department
Number of cycles	1 cycle must be performed, in which each of the points defined above must be tested at least once.
Number of DUTs	At least 6

7.18.2.1 Test sequence

This test must be performed after the tests "Damp heat, constant" and "Damp heat, cyclic."

After the "Damp heat, constant" test, the DUTs must be ventilated for 30 min before the measurement of the insulation resistance is carried out.

The insulation resistance must be measured immediately after the "Damp heat, cyclic" test.

7.18.3 Requirement

The insulation resistance must be at least 10 MΩ.
Functional state A must be verified after the test.

7.19 E-19 Quiescent current

7.19.1 Purpose

This test is meant to determine the quiescent-current draw of the component.

7.19.2 Test

For components with a delayed cut-off function (e.g., fan), the quiescent-current draw must be determined after this function has stopped.

The component must be measured with the associated peripherals and circuitry.

Table 39: Test parameters for E-19 Quiescent current

Operating mode of the DUT	Operating mode "Operation _{min} "
Test voltage	12.5 V (+4%, 0%)
Number of DUTs	At least 6
Test case 1	
T	T _{min}
Test case 2	
T	T _{RT}
Test case 3	
T	T _{max}

7.19.3 Requirement

A target quiescent-current draw of 0 mA applies to all DUTs.

For DUTs that must be operated after t.15 OFF, a quiescent-current draw equivalent (averaged over 12 h) of ≤ 0.1 mA corresponding to 1.2 mAh (above +40 °C, ≤ 0.2 mA) applies in the idle phase. This value must be adhered to under any conceivable idle conditions of the vehicle and over any 12-h period. Otherwise, a release by the department responsible for quiescent-current management is required.

Post-run functions must also be released by the department responsible for quiescent-current management.

7.20 E-20 Dielectric strength

7.20.1 Purpose

This test simulates the dielectric strength between components of the DUT that are galvanically isolated from each other, e.g., connector pins, relays, windings, or lines. The test must be performed on components that contain or control inductive subcomponents.

7.20.2 Test

Table 40: Test parameters for E-20 Dielectric strength

Operating mode of the DUT	Operating mode "Operation _{min} "
Test voltage V_{RMS}	500 V AC, 50 Hz, sinusoidal
Test duration	60 s
Test points	Application of the test voltage <ul style="list-style-type: none"> - To terminals without a galvanic connection - Between connection pins and conductive housing without a galvanic connection - Between connection pins and an electrode around the housing if the housing is non-conductive - To additional test points agreed upon with the appropriate department
Number of cycles	1 cycle must be performed, in which each of the points defined above must be tested at least once.
Number of DUTs	At least 6

7.20.2.1 Test sequence

This test must be performed after the tests "Damp heat, constant" and "Damp heat, cyclic."

After the "Damp heat, constant" test, the DUTs must be ventilated for 30 min before the measurement of the insulation resistance is carried out.

The insulation resistance must be measured immediately after the "Damp heat, cyclic" test.

7.20.3 Requirement

Functional state C

Dielectric breakdowns and electric arcs are not permissible.

7.21 E-21 Backfeeds

7.21.1 Purpose

The independence of switched terminals must be ensured.
This test verifies that the DUT is free of backfeeds to switched terminals (t.15, t.87, t.30c, etc.).

7.21.2 Test

Table 41: Test parameters for E-21 Backfeeds

Operating mode of the DUT	Operating mode "Operation _{max} "	
V _{test}	V _{opmax} - 0.2 V	
Test temperatures	T _{max} , T _{RT} , and T _{min}	
Test case 1	Severity 1	Severity 2
R	Not present	≥ 10 kΩ
S1	Open	Open
S2	Closed	Closed
Test case 2		
R	≥ 10 kΩ	
S1	Open	
S2	Open	
Number of DUTs	At least 6	

7.21.2.1 Test sequence

The DUT must be connected according to the circuitry in the vehicle (including sensors, actuators, etc.) and operated in normal operation. Switches S1 and S2 are closed. The voltage curve at the terminal being tested must be measured during switch-off of the terminal. To do this, the switches must be opened as per Table 41.

The terminal must be switched off, e.g., by means of a relay or a switch ($R_{\text{switch_open}} \rightarrow \infty$). Other possible voltage sources, such as t.30, must not be disconnected or switched off during the test (according to the behavior in the vehicle). The voltage curve at the terminal being tested must be measured using a measuring device (V) with an input resistance of ≥ 10 MΩ (e.g., oscilloscope).

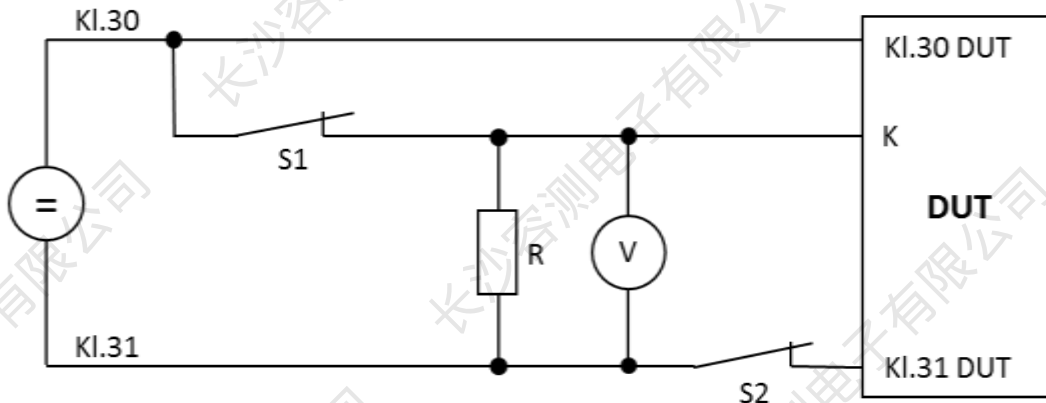

Figure 23: Schematic circuit diagram of test

KI. 30	t.30
V	V
KI. 30 DUT	DUT t.30
K	t
KI. 31 DUT	DUT t.31
KI. 31	t.31

Legend

- S1 Switch 1
- S2 Switch 2
- R Resistor
- t Terminal being tested
- V Measuring device

7.21.3 Requirement

Voltage backfeeds to the terminal being tested are permissible only up to a maximum level of 1 V. This voltage range must be achieved within $t = 20$ ms from the time of the switch-off.

The voltage at the non-wired terminal being tested must drop below a voltage of 1 V within $t = 20$ ms from the time of the switch-off.

The voltage curve over time must continuously fall. Discontinuity of the curve due to positive pulses is not permitted.

7.22 E-22 Overcurrents

7.22.1 Purpose

This test examines the overcurrent strength of mechanical switches, electronic outputs, and contacts. Higher currents than in the normal load case (e.g., maximum stalling current I_{stall} of a motor) must also be taken into account.

7.22.2 Test

Table 42: Test parameters for E-22 Overcurrents

Operating mode of the DUT	Operating mode "Operation _{max} "
Temperature	T_{max}
Test condition for electronic outputs	The output must be able to withstand at least three times the nominal load without damage.
t_{test}	30 min
Test conditions for switched outputs	For components with $I_N \leq 10$ A: $I_{test} = 3 * I_N$ For components with $I_N > 10$ A: $I_{test} = 2 * I_N$, but min. 30 A and max. 150 A For components with $I_{stall} > 3 * I_N$: $I_{test} = I_{stall}$ Under load, switch "OFF," "ON," and "OFF" again once. Load duration: 10 min In the case of multiple-contact relays and multiple-contact switches, each contact must be tested individually.
Number of DUTs	At least 6

7.22.3 Requirement

Functional state A for mechanical components without a fuse. If fuses are present in the load circuit, it is permissible for them to trip.

Functional state C for electronic outputs with overload detection (current, voltage, temperature).

In addition, no harmful changes that restrict the function or service life must be visible in a visual inspection of all components (visual and electrical characteristics).

7.23 E-23 Equalizing currents of multiple supply voltages

7.23.1 Purpose

For components with multiple supply voltage inputs independent of each other, e.g., if voltage is supplied by 12-V electric subsystems independent of each other, this test determines the internal independence of these supply branches.

7.23.2 Test

Table 43: Test parameters for E-23 Equalizing currents

Operating mode of the DUT	Operating mode "Assembly _{assembly} "
t_{test}	60 s
Test points	Application of the test voltage between – Both supply connections – Additional test points agreed upon with the appropriate department See Figure 24.
Number of cycles	1
Number of DUTs	6
Test case 1	
V_{test}	32 V
Test case 2	
V_{test}	-32 V

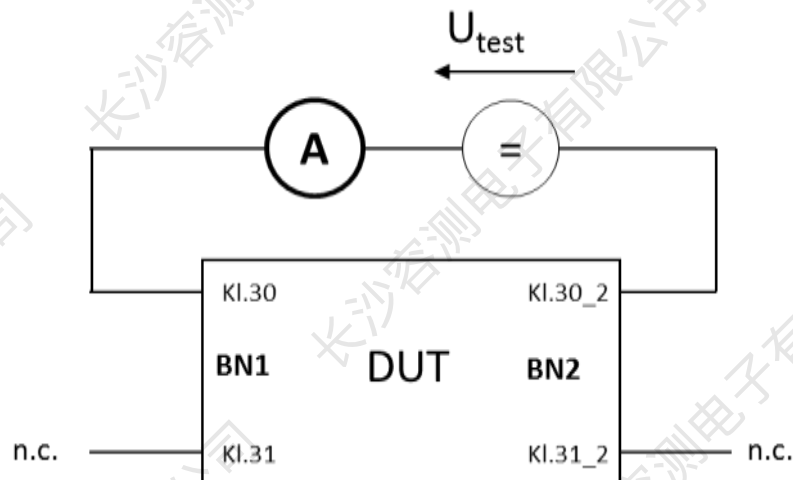

Figure 24: Schematic circuit diagram for E-23 Equalizing currents

U_{test}	V_{test}
KI.30	t.30
KI.30_2	t.30_2
BN1	Electric system 1
BN2	Electric system 2
KI.31	t.31
KI.31_2	t.31_2

7.23.3 Requirement

The equalizing current measured in the test setup must not exceed 100 μA . A single fault must not override or jeopardize the independence of the supply branches. Functional state A must be verified after the test.

Part II – Environmental requirements and tests

8 Use profile

8.1 Service life requirements

Table 44 shows the typical parameters for service life requirements.

Table 44: Service life requirements

Service life	15 years
Duration of driving operation	8 000 h
Mileage	300 000 km

For vehicles with an electric drive, it may be necessary to take additional operating situations into account (see section 4.3).

The operating duration in the following additional operating situations (see section 4.3)

- Duration of charging operation
- Duration of preconditioning operation
- Duration of on-grid parking operation

must be defined in the Performance Specification on a component-specific basis.

8.2 Temperature load spectra

In addition to the specification of minimum ambient temperature T_{\min} and maximum ambient temperature T_{\max} , the distribution indicating how long the component is exposed to the various temperatures between T_{\min} and T_{\max} must also be specified, in order to fully describe the temperature load to which the component is exposed at the point of use in the vehicle.

For vehicles with an alternative powertrain, a distinction must be made between operating situations "Driving," "Charging," "Preconditioning," and "On-grid parking" and the respective temperature load spectra must be specified both for the ambient temperature and for the coolant circuit temperature.

This temperature distribution is fundamentally a continuous distribution, because the ambient temperature of the component may be any value between T_{\min} and T_{\max} . For the design of the component and for the simplified calculation of test durations using the accelerated service-life model according to the Arrhenius equation (see Appendix D), this continuous distribution can be described well by several discrete temperature data points $T_{\text{field},i}$. For each temperature data point, the percentage share p_i of the operating duration during which the component is exposed to the data-point temperature must be specified.

The corresponding temperature load spectrum therefore has the following general form:

Table 45: Temperature load spectrum

Temperature in °C	Distribution
$T_{\text{field},1} = T_{\text{min}}$	p_1
$T_{\text{field},2}$	p_2
...	...
$T_{\text{field},n} = T_{\text{max}}$	p_n

This is based mainly on field measurements and technical experience.

Typical temperature load spectra for "Driving" operating situation in terms of different installation areas are indicated in Appendix B.

The usability of these typical temperature load spectra for a specific component must be verified, e.g., by vehicle measurement, simulation, or experience. In case of deviations, the temperature load spectrum must be adapted to the particular component.

A component-specific temperature load spectrum must be defined for special points of use or installed conditions (e.g., at a point of use near a heat source).

The temperature load spectrum that applies must be documented in the Performance Specification.

In addition to the typical temperature load spectra, typical values for the average temperature rise of a component in the vehicle during "Driving" operating situation are specified in Appendix B.

For temperature load spectra that are defined or adapted on a component-specific basis, this value must also be defined on a component-specific basis and documented in the Performance Specification.

9 Test selection

9.1 Test selection table

Table 46: Test selection table

Test	To be applied to	Required specification
M-01 Free fall	All components For components that will obviously be damaged during the test (e.g., glass bodies, highly sensitive transducers), this test may be omitted in agreement with the purchaser. This must be documented.	None
M-02 Stone impact test	Components installed in areas that may be affected by stone impact	None
M-03 Dust test	All components	IP degree of protection
Degree of protection IP6KX	Components for which the ingress of dust is not permissible	
Degree of protection IP5KX	Components for which the ingress of dust is permissible, but only as long as function and safety are not impaired	
M-04 Vibration test	All components	Vibration profile
- As per vibration profile A	Components installed on the engine	
- As per vibration profile B	Components installed on the transmission	
- As per vibration profile C	Components installed at the decoupled intake manifold	
- As per vibration profile D	Components installed on sprung masses (body)	
- As per vibration profile E	Components installed on unsprung masses (wheel, suspension)	
M-05 Mechanical shock	All components	None
M-06 Continuous mechanical shock	Components mounted in or on doors, hoods, and tailgates/trunk lids	Number of shocks
K-01 High-/low-temperature aging	All components	None
K-02 Incremental temperature test	All components	None
K-03 Low-temperature operation	All components	None
K-04 Repainting temperature	Components installed in the exterior area which may be subjected to increased temperatures in the event of repainting	None
K-05 Thermal shock (component)	All components	Test method (Na or Nc), if Nc: test medium
As per DIN EN 60068-2-14 Na (air-to-air)	Components that are not permanently operated in a fluid	
As per DIN EN 60068-2-14 Nc (medium-to-medium)	Components that are permanently operated in a fluid (IP X8)	
K-06 Salt spray test with operation, exterior	Components mounted in the exterior area, underbody, or engine compartment	None

Test	To be applied to	Required specification
K-07 Salt spray test with operation, interior	Components installed at exposed points in the vehicle interior (e.g., side pockets in the luggage compartment, door wet space, spare wheel well)	None
K-08 Damp heat, cyclic	All components	None
K-09 Damp heat, cyclic (with frost)	All components	None
K-10 Water protection – IPX0 to IPX6K	All components	IP degree of protection
- Degree of protection IPX0	Components that do not require water protection	
- Degree of protection IPX1	Components for which vertically falling drops must have no harmful effect	
- Degree of protection IPX2	Components with a tilt of up to 15° in the installation position, for which vertically falling drops must have no harmful effect	
- Degree of protection IPX3	Components for which spray water must have no harmful effect	
- Degree of protection IPX4K	Components for which splash water with increased pressure must have no harmful effect	
- Degree of protection IPX5	Components for which water jets must have no harmful effect	
- Degree of protection IPX6K	Components for which powerful water jets with increased pressure must have no harmful effect	
K-11 High-pressure cleaning/pressure washing	Components that may be directly exposed to high-pressure cleaning/pressure washing or underbody washing	None
K-12 Thermal shock with splash water	Components installed in the exterior area or engine compartment which are expected to be exposed to splash water (e.g., when driving through puddles).	None
K-13 Thermal shock – immersion	Components installed below the fording depth for which temporary immersion in (salt) water is to be expected (e.g., when driving through water) (IPX7)	None
K-14 Damp heat, constant	All components	Severity

Test	To be applied to	Required specification
K-15 Condensation and climatic test	<p>The necessity of the test must be evaluated on a component-specific basis. If required, the necessity of the test must be indicated in the Performance Specification.</p> <p>If the test is indicated in the Performance Specification, the test can be performed as test K-15 a Condensation test with modules or as test K-15 b Climatic test for components with watertight housings for components with watertight housings; the test must be performed as test K-15 a Condensation test with modules for components without a watertight housing.</p>	None
K-16 Thermal shock (without housing)	Modules of all components	None
K-17 Solar radiation	Components exposed to direct solar radiation in the installation position	Test profile
K-18 Harmful gas test	Components with open plug contacts and switching contacts	None
C Chemical tests	All components	Chemicals Operating mode
L-01 Service life test – Mechanical/hydraulic durability testing	Components with mechanical/hydraulic actuation/function cycles, e.g., brake actuations, seat adjustment cycles, switch/button actuations	Number of function/actuation cycles
L-02 Service life test – High-temperature durability testing	All components	Test duration
L-03 Service life test – Temperature cycle durability testing	All components	Number of test cycles

9.2 Test sequence plan

A component-specific test sequence plan must be defined in the Performance Specification.

A test sequence plan is provided in Appendix A as a basis of discussion for collaborative projects between several original equipment manufacturers (OEMs) (e.g., industry modular assembly matrix or IBK).

10 Mechanical requirements and tests

10.1 M-01 Free fall

10.1.1 Purpose

This test simulates the free fall of a component to the floor, as it may occur anytime throughout the process chain before the component is properly installed.

It is meant to ensure that, in the event of a drop, a component that appears visibly undamaged and is therefore installed in the vehicle, does not have any concealed damage or premature damage, e.g., internal subcomponent detachments or cracks.

10.1.2 Test

Table 47: Test parameters for M-01 Free fall

Operating mode of the DUT	Assembly _{not installed}
Drop height	1 m
Impact surface	Concrete floor
Test cycle	For each of the 3 DUTs, one drop in both directions of a spatial axis (1st DUT: $\pm X$, 2nd DUT: $\pm Y$, 3rd DUT: $\pm Z$)
Number of DUTs	3

10.1.3 Requirement

The DUT must be visually inspected with the naked eye and tested for loose or rattling parts by shaking.

- If the DUT is visibly damaged, this damage must be documented in the test report.
- If the DUT is not visibly damaged, it must be fully functional after the test, and all parameters must be within the specifications. This is verified by means of a P-03 Parameter test (large) as per section 4.7.3.
- Concealed damage is not permissible.

10.2 M-02 Stone impact test

10.2.1 Purpose

This test simulates the mechanical load on the component due to stone impact. It is meant to verify the resistance of the component to flaw patterns, e.g., deformation or cracks.

10.2.2 Test

The test is performed on the basis of DIN EN ISO 20567-1, test method B, with the following parameters:

Table 48: Test parameters for M-02 Stone impact test

Operating mode of the DUT	Assembly _{assembly}
Quantity of blasting medium	500 g
Test pressure	2 bar
Blasting material	Chilled iron grit as per DIN EN ISO 11124-2, grain size 4 to 5 mm
Test surface on DUT	All surfaces that are freely accessible on the vehicle
Impact angle	54° relative to blasting direction
Testing equipment	Multiple stone-impact test device as per DIN EN ISO 20567-1
Number of cycles	2
Number of DUTs	6

10.2.3 Requirement

The DUT must be fully functional before and after the test, and all parameters must meet the specifications. This is verified by means of a P-02 Parameter test (small) as per section 4.7.2.

In addition, the DUT must be visually inspected with the naked eye and tested for loose or rattling parts by shaking.

Changes/damage must be documented in the test report and evaluated together with the purchaser.

An evaluation based on the characteristic values in DIN EN ISO 20567-1 is not required.

10.3 M-03 Dust test

10.3.1 Purpose

This test simulates the dust load of the component during vehicle operation. It is meant to verify the resistance of the component to electrical and mechanical error/flaw patterns.

10.3.2 Test

The test is carried out as per ISO 20653 with the following parameters:

Table 49: Test parameters for M-03 Dust test

Operating mode of the DUT	For electrical/electronic components: "Operation _{min} " For mechatronic components (e.g., for components with rotating parts, controls): "Operation _{max} " and "Operation _{min} " intermittently as per Figure 25.
Test setup	Vertical flow direction as per ISO 20653:2006, figure 1
Degree of protection to be achieved	As defined in the Performance Specification
Test duration	20 cycles of 20 minutes each
Number of DUTs	6

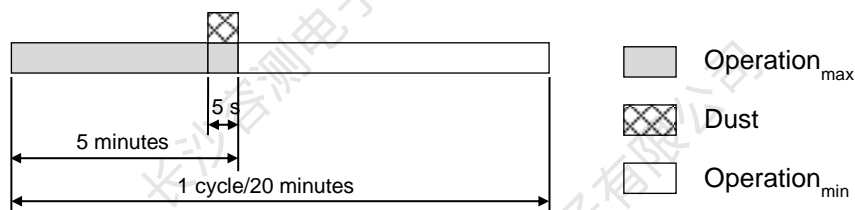

Figure 25: Test sequence for M-03 Dust test

When performing the test, the as-installed position of the component in the vehicle must be recreated. The test setup (as-installed position, covers, trim panels, situation during operation) must be suggested by the contractor, approved by the purchaser, and documented.

10.3.3 Requirement

The required degree of protection defined in the Performance Specification as per ISO 20653 must be achieved.

The DUT must be fully functional before, during, and after the test, and all parameters must be within the specifications. This is verified by means of a P-02 Parameter test (small) as per section 4.7.2.

In addition, the DUT must be visually inspected with the naked eye. Changes or damage must be documented in the test report and evaluated together with the purchaser.

10.4 M-04 Vibration test

10.4.1 Purpose

These tests simulate the vibrational load on the component during "Driving" operating situation.

They are meant to verify the resistance of the component to flaw patterns, such as subcomponent detachments and material fatigue.

10.4.2 Test

The test is performed on the basis of ISO 16750, part 3.

The test is carried out as per DIN EN 60068-2-6 for sinusoidal vibration excitation and DIN EN 60068-2-64 for wide-band vibration excitation, with the following parameters:

Table 50: General vibration test parameters

Operating mode of the DUT	"Driving _{min} " and "Driving _{max} " intermittently (see Figure 26)
Superimposed temperature curve	Repeating as per Figure 26 and Table 44
Frequency sweep time for sinusoidal excitation	1 octave/min, logarithmic
Vibration profile A (for components installed on the engine)	Vibration excitation, sinusoidal as per Figure 27 and Table 52 Vibration excitation, wide-band random vibration as per Figure 28 and Table 53
Vibration profile B (for components installed on the transmission)	Vibration excitation, sinusoidal as per Figure 29 and Table 54 Vibration excitation, wide-band random vibration as per Figure 30 and Table 55
Vibration profile C (for components installed at the decoupled intake manifold)	Vibration excitation, sinusoidal as per Figure 31 and Table 56
Vibration profile D (hang-on parts, for components installed on sprung masses)	Vibration excitation, wide-band random vibration as per Figure 32 and Table 57
Vibration profile E for unsprung masses (chassis)	Vibration excitation, wide-band random vibration as per Figure 33 and Table 58
Number of DUTs	6

Components that are installed on an electric machine must be tested at least as per vibration profile D. However, this test profile does not take into account the specific vibration loads that emanate from an electric machine. But in practice, these specific vibration loads can occur and act as a load on the component. Therefore, the specific vibration loads that emanate from an electric machine must be taken into account

during the test. For this purpose, measurements are required on the electric machine in question.

When performing the test, the as-installed position of the component in the vehicle must be recreated.

The manner of fastening connected lines (e.g., electric wiring, coolant hoses, hydraulic lines) in the test setup must be defined together with the purchaser.

For components that are installed on the bracket or vehicle by means of damping elements, it must be specified with the purchaser whether

- all DUTs must be tested with damping elements,
- all DUTs must be tested without damping elements, or
- three DUTs must be tested with damping elements and three DUTs must be tested without damping elements.

The sampling rate must be selected in such a way that interruptions and short circuits can be unambiguously detected.

Additional tests for verifying the strength of the whole system, consisting of the assembly of component, bracket, and add-on parts, must be agreed upon with the purchaser.

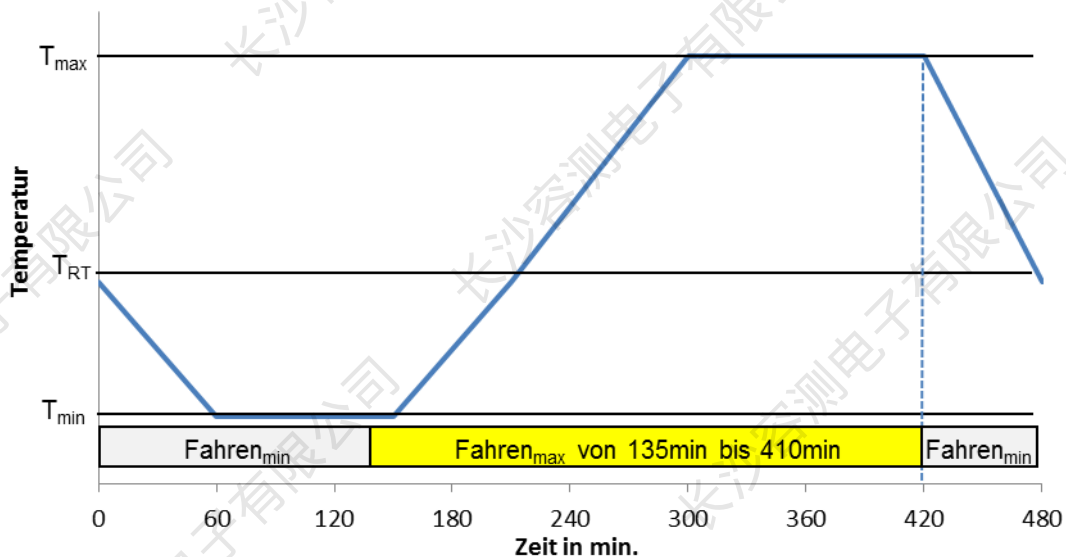

Figure 26: Temperature curve for vibration

T_{max}	T_{max}
Temperatur	Temperature
T_{RT}	T_{RT}
T_{min}	T_{min}
Fahren _{min}	Driving _{min}
Fahren _{max} von 135min bis 410min	Driving _{max} from 135 min to 410 min
Zeit in min.	Time in min

Table 51: Temperature curve for vibration

Time in min	Temperature in °C
0	T_{RT}
60	T_{min}
150	T_{min}
300	T_{max}
410	T_{max}
480	T_{RT}

If a coolant circuit is present, the coolant temperature must track the respective test temperature to the limits $T_{cool,min}$ and $T_{cool,max}$. Only the ambient temperature is varied outside of the coolant temperature limits.

10.4.2.1 Vibration profile A (components installed on the engine)

Table 52: Test parameters – Vibration, sinusoidal for engine-mounted parts

Vibration excitation	Sinusoidal	
Test duration for each spatial axis	22 h	
Vibration profile	<p>Curve 1 applies to components mounted on engines with no more than 5 cylinders. Curve 2 applies to components mounted on engines with 6 or more cylinders.</p> <p>For components that can be used in both scenarios, the curves are combined.</p>	
Curve 1 in Figure27	Frequency in Hz	Amplitude of acceleration in m/s ²
	100	100
	200	200
	240	200
	270	100
	440	100
Curve 2 in Figure27	Frequency in Hz	Amplitude of acceleration in m/s ²
	100	100
	150	150
	440	150
Combination	Frequency in Hz	Amplitude of acceleration in m/s ²
	100	100
	150	150
	200	200
	240	200
	255	150
	440	150

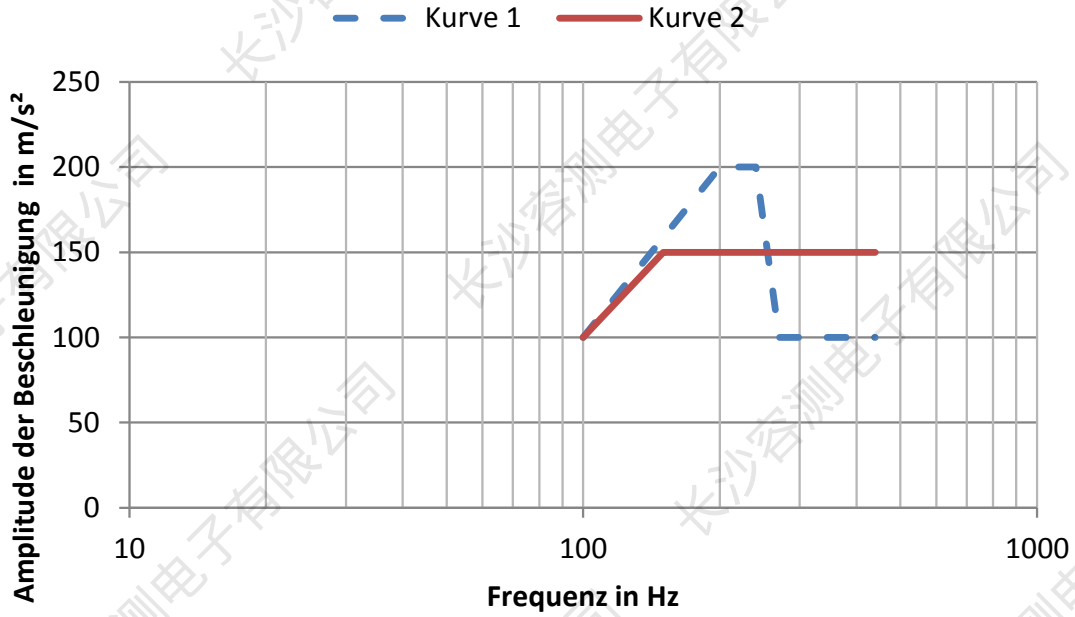

Figure27: Vibration profile, sinusoidal for engine-mounted parts

Kurve 1	Curve 1
Kurve 2	Curve 2
Amplitude der Beschleunigung in m/s ²	Amplitude of acceleration in m/s ²
Frequenz in Hz	Frequency in Hz

Table 53: Test parameters – Vibration, wide-band random vibration for engine-mounted parts

Vibration excitation	Wide-band random vibration	
Test duration for each spatial axis	22 h	
RMS value of acceleration	181 m/s ²	
Vibration profile Figure 28	Frequency in Hz	Power density spectrum in (m/s ²) ² /Hz
	10	10
	100	10
	300	0.51
	500	20
	2 000	20

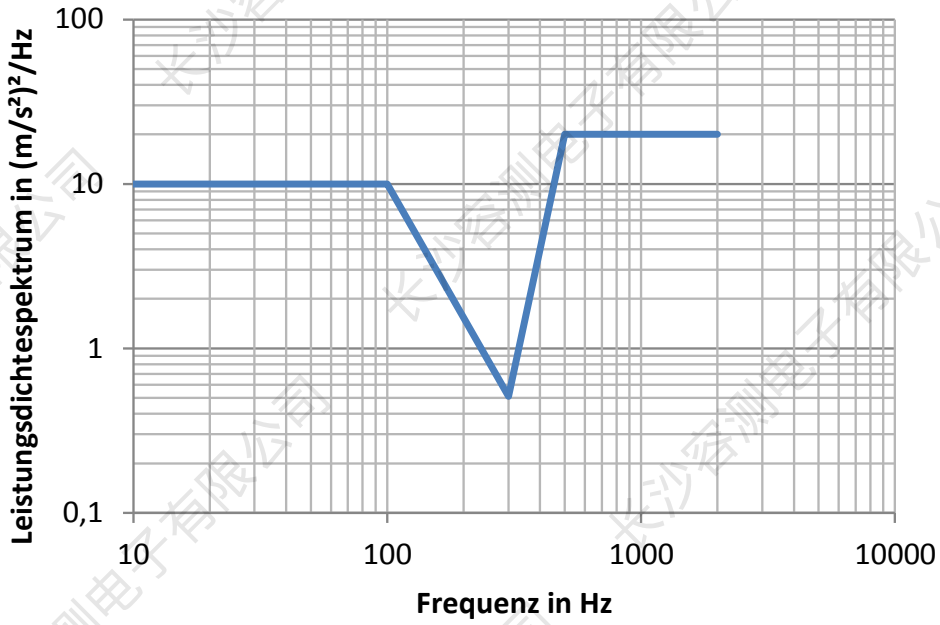

Figure 28: Vibration profile, wide-band random vibration for engine-mounted parts

Leistungsdichtespektrum in (m/s ²) ² /Hz	Power density spectrum in (m/s ²) ² /Hz
Frequenz in Hz	Frequency in Hz

10.4.2.2 Vibration profile B (components installed on the transmission)

Table 54: Test parameters – Vibration, sinusoidal for transmission-mounted parts

Vibration excitation	Sinusoidal	
Test duration for each spatial axis	22 h	
Vibration profile Figure 29	Frequency in Hz	Amplitude of acceleration in m/s ²
	100	30
	200	60
	440	60

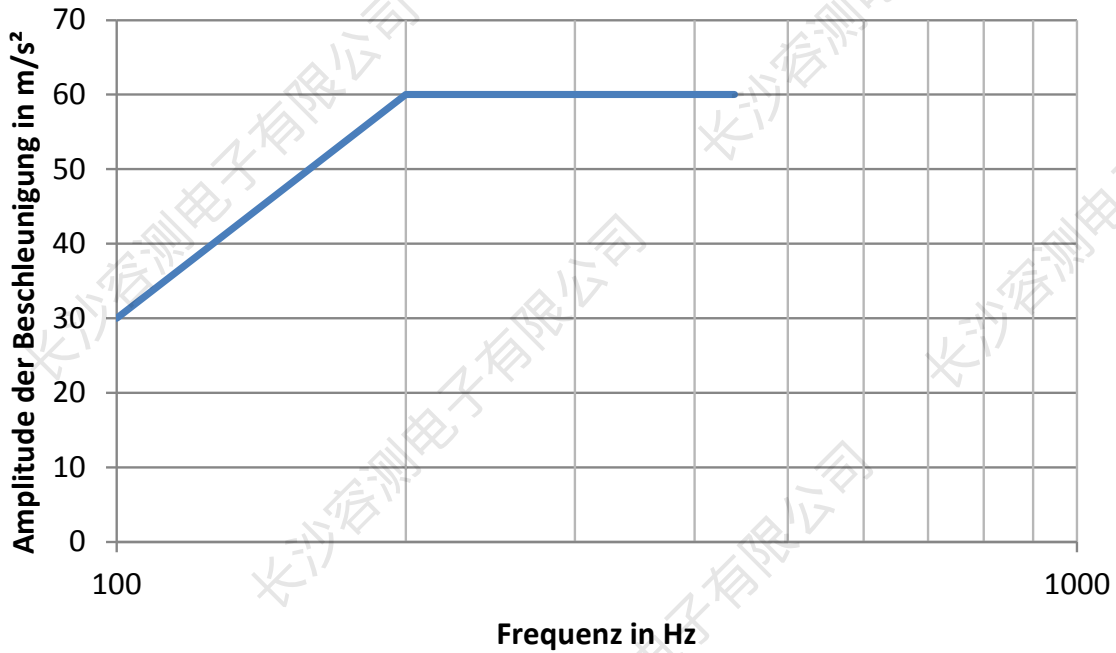

Figure 29: Vibration profile, sinusoidal for transmission-mounted parts

Amplitude der Beschleunigung in m/s ²	Amplitude of acceleration in m/s ²
Frequenz in Hz	Frequency in Hz

Table 55: Test parameters – Vibration, wide-band random vibration for transmission-mounted parts

Vibration excitation	Wide-band random vibration	
Test duration for each spatial axis	22 h	
RMS value of acceleration	96.6 m/s ²	
Vibration profile Figure 30	Frequency in Hz	Power density spectrum in (m/s ²) ² /Hz
	10	10
	100	10
	300	0.51
	500	5
	2 000	5



Figure 30: Vibration profile, wide-band random vibration for transmission-mounted parts

Leistungsdichtespektrum in (m/s ²) ² /Hz	Power density spectrum in (m/s ²) ² /Hz
Frequenz in Hz	Frequency in Hz

10.4.2.3 Vibration profile C (components installed at the decoupled intake manifold)

Table 56: Test parameters, sinusoidal for components at the decoupled intake manifold

Vibration excitation	Sinusoidal	
Test duration for each spatial axis	22 h	
Vibration profile Figure 31	Frequency in Hz	Amplitude of acceleration in m/s ²
	100	90
	200	180
	325	180
	500	80
	1 500	80



Figure 31: Vibration profile, sinusoidal for components at the decoupled intake manifold

Amplitude der Beschleunigung in m/s ²	Amplitude of acceleration in m/s ²
Frequenz in Hz	Frequency in Hz

10.4.2.4 Vibration profile D (components installed on sprung masses (body))

Table 57: Test parameters, wide-band random vibration for sprung masses

Vibration excitation	Wide-band random vibration	
Test duration for each spatial axis	8 h	
RMS value of acceleration	30.8 m/s ²	
Vibration profile Figure 32	Frequency in Hz	Power density spectrum in (m/s ²) ² /Hz
	5	0.884
	10	20
	55	6.5
	180	0.25
	300	0.25
	360	0.14
	1 000	0.14
	2 000	0.14

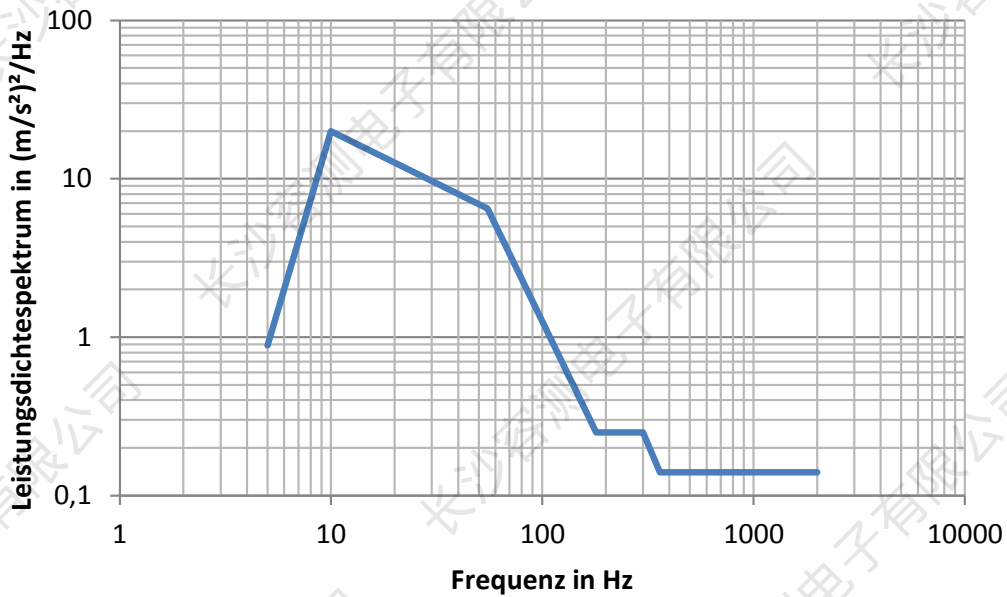

Figure 32: Vibration profile, wide-band random vibration for sprung masses

Leistungsdichtespektrum in (m/s ²) ² /Hz	Power density spectrum in (m/s ²) ² /Hz
Frequenz in Hz	Frequency in Hz

10.4.2.5 Vibration profile E (components installed on unsprung masses (wheel, suspension))

Table 58: Test parameters, wide-band random vibration for unsprung masses

Vibration excitation	Wide-band random vibration	
Test duration for each spatial axis	8 h	
RMS value of acceleration	107.3 m/s ²	
Vibration profile Figure 33	Frequency in Hz	Power density spectrum in (m/s ²) ² /Hz
	20	200
	40	200
	300	0.5
	800	0.5
	1 000	3
	2 000	3

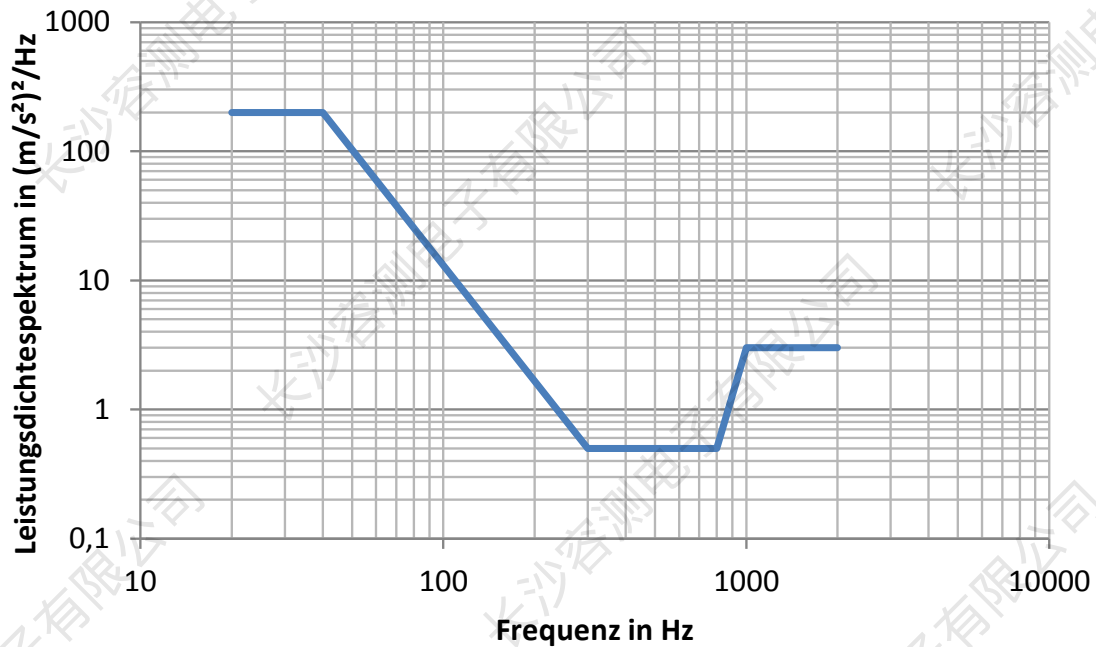

Figure 33: Vibration profile, wide-band random vibration for unsprung masses

Leistungsdichtespektrum in (m/s ²) ² /Hz	Power density spectrum in (m/s ²) ² /Hz
Frequenz in Hz	Frequency in Hz

10.4.3 Requirement

The DUT must be fully functional before, during, and after the test, and all parameters must be within the specifications. This is verified by means of continuous parameter monitoring and a P-03 Parameter test (large) as per section 4.7.3.

In addition, the DUT must be visually inspected with the naked eye and tested for loose or rattling parts by shaking.

10.5 M-05 Mechanical shock

10.5.1 Purpose

This test simulates the mechanical load on the component, e.g., when driving over curbs or in the case of car accidents.

It is meant to verify the resistance of the component to flaw patterns, such as cracks and subcomponent detachments.

10.5.2 Test

The test is carried out as per DIN EN 60068-2-27 with the following parameters:

Table 59: Test parameters for M-05 Mechanical shock

Operating mode of the DUT	"Driving _{min} " and "Driving _{max} " intermittently
Peak acceleration	500 m/s ²
Shock duration	6 ms
Pulse shape	Half-sine
Number of shocks per direction ($\pm X$, $\pm Y$, $\pm Z$)	10
Number of DUTs	6

When performing the test, the as-installed position of the component in the vehicle must be recreated.

The test must be performed without brackets or add-on parts. The manner of fastening connected lines (e.g., electric wiring, coolant hoses, hydraulic lines) in the test setup must be defined together with the purchaser.

For components that are installed on the bracket or vehicle by means of damping elements, it must be specified with the purchaser whether

- all DUTs must be tested with damping elements,
- all DUTs must be tested without damping elements, or
- three DUTs must be tested with damping elements and three DUTs must be tested without damping elements.

The time between the shock pulses must be long enough to ensure complete decay of the previous vibration.

10.5.3 Requirement

The DUT must be fully functional before, during, and after the test, and all parameters must be within the specifications. This is verified by means of continuous parameter monitoring and a P-02 Parameter test (small) as per section 4.7.2.

In addition, the DUT must be visually inspected with the naked eye and tested for loose or rattling parts by shaking.

10.6 M-06 Continuous mechanical shock

10.6.1 Purpose

This test simulates the acceleration forces of components that are installed in doors, hoods, or tailgates/trunk lids and are exposed to high accelerations during opening and closing.

They are meant to verify the resistance of the component to flaw patterns, such as subcomponent detachments and material fatigue.

10.6.2 Test

The test is carried out as per DIN EN 60068-2-29 with the following parameters:

Table 60: Test parameters for M-06 Continuous mechanical shock

Operating mode of the DUT	Operation _{max}											
Peak acceleration	300 m/s ²											
Shock duration	6 ms											
Pulse shape	Half-sine											
Number of shocks	<table border="1"> <thead> <tr> <th>Installation area</th> <th>Number of shocks</th> </tr> </thead> <tbody> <tr> <td>Driver door</td> <td>100 000</td> </tr> <tr> <td>Front passenger door and rear doors</td> <td>50 000</td> </tr> <tr> <td>Trunk lid/tailgate</td> <td>30 000</td> </tr> <tr> <td>Hood</td> <td>3 000</td> </tr> </tbody> </table>		Installation area	Number of shocks	Driver door	100 000	Front passenger door and rear doors	50 000	Trunk lid/tailgate	30 000	Hood	3 000
	Installation area	Number of shocks										
	Driver door	100 000										
	Front passenger door and rear doors	50 000										
	Trunk lid/tailgate	30 000										
	Hood	3 000										
If the component is installed in several installation areas, the one with the highest number of shocks must be selected.												
As-installed position	The DUT must be mounted on the test device according to its installed condition in the vehicle.											
Number of DUTs	6											

10.6.3 Requirement

The DUT must be fully functional before, during, and after the test, and all parameters must be within the specifications. This is verified by means of continuous parameter monitoring and a P-02 Parameter test (small) as per section 4.7.2. In addition, the DUT must be visually inspected with the naked eye and tested for loose or rattling parts by shaking.

10.7 M-07 Coolant circuit pressure pulsation test

10.7.1 Purpose

This test simulates the load on the component due to fluctuations in coolant pressure, as well as the states during the post-heating phase and vacuum filling of the cooling system. It must be applied exclusively to components that are connected to a coolant circuit.

It is meant to verify the mechanical strength of the components affected by pressure fluctuations in the coolant circuit (e.g., cooling plates of the power module).

10.7.2 Test

Table 61: Test parameters for M-07 Coolant circuit pressure pulsation test

Operating mode of the DUT	Assembly _{assembly}
Test procedure	Part 1 – Pressure pulsation test: Minimum test pressure P_{\min} : 0.5 (-0.1) bar _{abs} Maximum test pressure P_{\max} : 2.0 (+0.1) bar _{abs} Pressure pulsation frequency: 25-35 1/min Number of pressure pulsations: 100 000 Test temperature: $T_{\text{cool,max}}$ Part 2 – Overpressure test: Test pressure P : 4.0 (+0.1) bar _{abs} Test duration: 1 h Test temperature: $T_{\text{cool,max}}$ Part 3 – Underpressure test (without test medium): Test pressure P : 0.01 (-0.01) bar _{abs} Test duration: 30 min Test temperature: T_{RT}
Test medium	Must be agreed upon with the purchaser.
Number of DUTs	6

10.7.3 Requirement

The DUT must be fully functional before and after the test, and all parameters must meet the specifications. This is verified by means of a P-03 Parameter test (large) as per section 4.7.3.

11 Climatic requirements and tests

11.1 K-01 High-/low-temperature aging

11.1.1 Purpose

This test simulates the thermal load on the component during storage and transport. It is meant to verify the resistance to storage at high or low temperatures, e.g., during component transport (by plane, shipping container).

If the test is carried out at the start of a test sequence, it is also used to adjust all components to the same initial conditions.

11.1.2 Test

Table 62: Test parameters for K-01 High-/low-temperature aging

Operating mode of the DUT	Assembly _{not installed}
Test duration and test temperature	2 cycles of 24 h each (each consisting of 12 h of aging at T_{\min} and 12 h of aging at T_{\max})
Number of DUTs	As specified in the test sequence plan in the Performance Specification.

11.1.3 Requirement

The DUT must be fully functional before and after the test, and all parameters must meet the specifications. This is verified by means of a P-03 Parameter test (large) as per section 4.7.3.

In addition, the DUT must be visually inspected with the naked eye and tested for loose or rattling parts by shaking.

11.2 K-02 Incremental temperature test

11.2.1 Purpose

This test simulates operation of the component at different ambient temperatures. It is meant to safeguard the component against any malfunctions which may occur within a narrow interval of the ambient temperature range, as well as the startup behavior of the components over the entire ambient temperature range.

11.2.2 Test

Table 63: Test parameters for K-02 Incremental temperature test

Operating mode of the DUT	"Operation _{max} " during the P-01 Parameter test (function check) as per section 4.7.1; otherwise, "Operation _{min} "
Test temperature	The DUTs must be exposed to a temperature profile as per Figure 34. The temperature change per increment is 5 °C.
Test sequence	The DUT must be held at every temperature increment until it has reached complete temperature stabilization (see section 4.6). A P-01 Parameter test (function check) as per section 4.7.1 must then be performed.
Number of DUTs	As specified in the test sequence plan in the Performance Specification, but at least 6

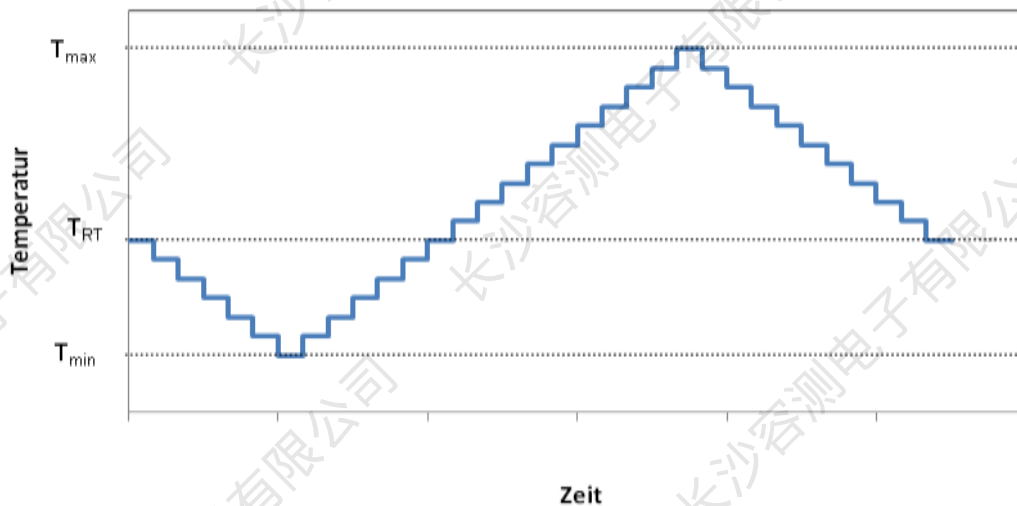

Figure 34: Temperature profile for incremental temperature test

T_{max}	T_{max}
T_{RT}	T_{RT}
T_{min}	T_{min}
Temperatur	Temperature
Zeit	Time

If a coolant circuit is present, the coolant temperature must track the respective test temperature to the limits $T_{cool,min}$ and $T_{cool,max}$. Only the ambient temperature is varied outside of the coolant temperature limits.

11.2.3 Requirement

All DUT parameters must be within the specifications during each P-01 Parameter test (function check) as per section 4.7.1.

11.3 K-03 Low-temperature operation

11.3.1 Purpose

This test simulates the load on the component at low temperatures. It is meant to verify the function of the component after a long parking time or driving time at extremely low temperatures.

11.3.2 Test

The test is performed as per DIN EN 60068-2-1, test Ab, with the following parameters:

Table 64: Test parameters for

K-03 Low-temperature operation

Operating mode of the DUT	12 h "Off-grid parking _{min} " (t.30 of component at V _{opmin}) 12 h "Operation _{max} " at V _{opmin} 12 h "Off-grid parking _{min} " (t.30 of component at V _{op}) 12 h "Operation _{max} " at V _{op}
Test duration	48 h
Test temperature	T _{min}
Number of DUTs	6

The test as per DIN EN 60068-2-1, test Ab, must also be performed for components that give off heat.

If a coolant circuit is present, the minimum coolant temperature T_{cool,min} must be set.

For components with high power loss, an increase in the test chamber temperature above T_{min} as a result of self-heating is permissible during the test in operating mode "Operation_{max}," in agreement between the contractor and the purchaser.

11.3.3 Requirement

The DUT must be fully functional before, during, and after the test, and all parameters must be within the specifications. This is verified by means of continuous parameter monitoring and a P-02 Parameter test (small) as per section 4.7.2.

11.4 K-04 Repainting temperature

11.4.1 Purpose

This test simulates the load on the component during repainting. It is meant to safeguard the component against thermally induced flaw patterns, e.g., cracking in solder joints, adhesive joints, bonded joints, and welded joints, and at seals and housings.

11.4.2 Test

Table 65: Test parameters for K-04 Repainting temperature

Operating mode of the DUT	Off-grid parking _{min}
Test duration and test temperature	15 min at 130 °C and 1 h at 110 °C
Number of DUTs	6

If a coolant circuit is present, the temperature of the idle coolant must be specified as T_{RT} .

11.4.3 Requirement

The DUT must be fully functional before and after the test, and all parameters must meet the specifications. This is verified by means of a P-02 Parameter test (small) as per section 4.7.2.

11.5 K-05 Thermal shock (component)

11.5.1 Purpose

This test simulates the thermal load on the component as a result of abrupt changes in temperature during vehicle operation.

It is meant to safeguard the component against thermally induced flaw patterns, e.g., cracking in solder joints, adhesive joints, bonded joints, and welded joints, and at seals and housings.

11.5.2 Test

The test is carried out as per DIN EN 60068-2-14 with the following parameters:

Table 66: Test parameters for K-05 Thermal shock (component)

Operating mode of the DUT	Assembly _{assembly}
Minimum temperature/temperature of the cold test bath	T_{\min}
Maximum temperature/temperature of the hot test bath	T_{\max}
Hold time at minimum/maximum temperature	15 min after complete temperature stabilization (see section 4.6)
Transfer duration (air-to-air, medium-to-medium)	≤ 30 s
Test fluid for test Nc	Fluid in which the component is operated in the vehicle
Test	As per DIN EN 60068-2-14 Na for components that are not permanently operated in a fluid As per DIN EN 60068-2-14 Nc for components that are permanently operated in a fluid (IP X8). The DUT must be immersed so that all sides of the DUT are covered by at least 25 mm of the test fluid.
Number of cycles	100
Number of DUTs	6

11.5.3 Requirement

The DUT must be fully functional before and after the test, and all parameters must meet the specifications. This is verified by means of a P-03 Parameter test (large) as per section 4.7.3.

Additionally for the medium-to-medium test:

The fluid must not penetrate the DUT. The DUT must not be opened until after the entire test sequence has been completed as per the test sequence plan (section 9.2).

11.6 K-06 Salt spray test with operation, exterior

11.6.1 Purpose

This test simulates the load on the component in a saline atmosphere with saline water, as it may occur in certain areas of the world or in winter road conditions. It is meant to safeguard the component against any malfunctions when exposed to a salt load, e.g., from short circuits and leakage currents due to the ingress of salt into the component.

11.6.2 Test

The test is carried out as per DIN EN 60068-2-11 with the following parameters:

Table 67: Test parameters for K-06 Salt spray test with operation, exterior

Operating mode of the DUT	During the spraying phase: 1 h "Off-grid parking _{min} " and 1 h "Operation _{max} ," intermittently During the resting phase: "Off-grid parking _{min} "
Test temperature	35 °C
Test cycle	Each test cycle consists of an 8-h spraying phase and a 4-h resting period as per Figure 35.
Number of test cycles	12 cycles For components with increased requirements for leak tightness as per section 4.9.1 (e.g., exposure of parked vehicle to water), the number of cycles must be adapted on a component-specific basis.
Number of DUTs	6

When performing the test, the as-installed position of the component in the vehicle must be recreated.

It is not permissible to clean the DUTs after the test.

If a coolant circuit is present, the coolant temperature must be set to the test temperature.

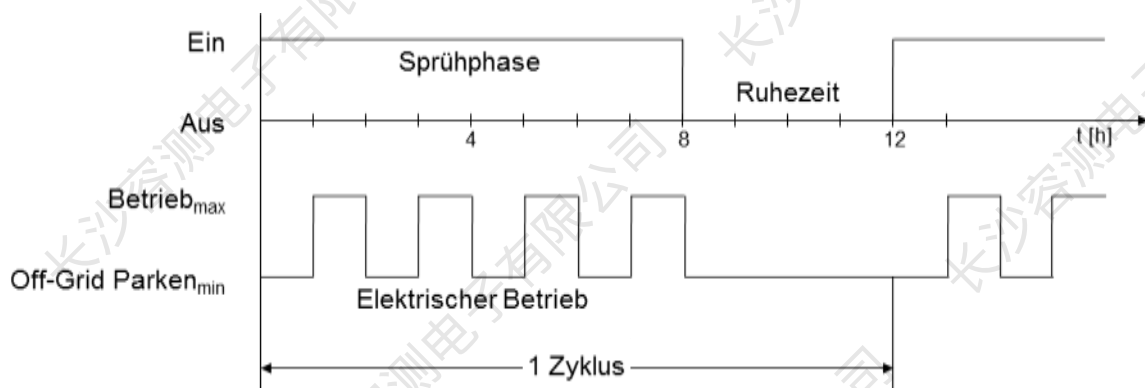

Figure 35: Salt spray test with operation, exterior – spraying phases

Ein	On
Aus	Off
Betrieb _{max}	Operation _{max}
Off-Grid Parken _{min}	Off-grid parking _{min}
Sprühphase	Spraying phase
Ruhezeit	Resting period
t [h]	t [h]
Elektrischer Betrieb	Electrical operation
1 Zyklus	1 cycle

11.6.3 Requirement

The DUT must be fully functional before, during, and after the test, and all parameters must be within the specifications. This is verified by means of continuous parameter monitoring and a P-02 Parameter test (small) as per section 4.7.2.

11.7 K-07 Salt spray test with operation, interior

11.7.1 Purpose

This test simulates the load on the component in a saline atmosphere, as it may occur in certain areas of the world. It is meant to safeguard the component against any malfunctions when exposed to a salt load, e.g., from short circuits and leakage currents due to the ingress of salt into the component.

11.7.2 Test

The test is carried out as per DIN EN 60068-2-11 with the following parameters:

Table 68: Test parameters for K-07 Salt spray test with operation, interior

Operating mode of the DUT	During the spraying phase: 55 min "Off-grid parking _{min} " and 5 min "Operation _{max} ," intermittently During the resting phase: "Off-grid parking _{min} "
Test temperature	35 °C
Test cycle	Each test cycle consists of an 8-h spraying phase and a 4-h resting period as per Figure 36.
Number of test cycles	2
Number of DUTs	6

When performing the test, the as-installed position of the component in the vehicle must be recreated. The test setup (as-installed position, covers, trim panels, situation during operation) must be suggested by the contractor, approved by the purchaser, and documented.

If a coolant circuit is present, the coolant temperature must be set to the test temperature.

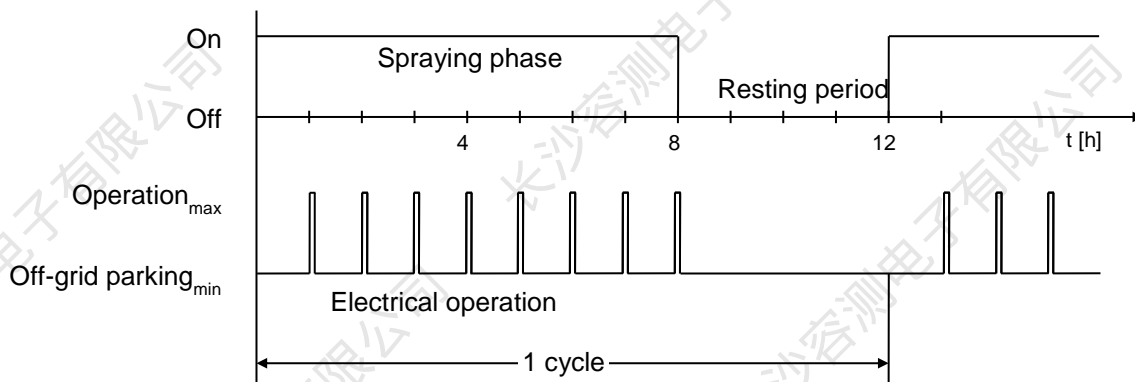

Figure 36: Salt spray test with operation, interior – spraying phases

11.7.3 Requirement

The DUT must be fully functional before, during, and after the test, and all parameters must be within the specifications. This is verified by means of continuous parameter monitoring and a P-03 Parameter test (large) as per section 4.7.3.

11.8 K-08 Damp heat, cyclic

11.8.1 Purpose

This test simulates the thermal load on the component by cyclic temperature changes with high humidity during vehicle operation.

It is meant to verify the resistance of the component to damp heat.

11.8.2 Test

The test is carried out as per DIN EN 60068-2-30 with the following parameters:

Table 69: Test parameters for K-08 Damp heat, cyclic

Operating mode of the DUT	"Operation _{max} " during the P-01 Parameter test (function check); otherwise, "Operation _{min} "
Total test duration	144 h
Test variant	Variant 1
Maximum test temperature	55 °C
Number of cycles	6
Number of DUTs	6

The P-01 Parameter test (function check) must be performed two times, once each after the maximum and minimum temperatures are reached.

If a coolant circuit is present, the coolant temperature must track the respective test temperature to the limits $T_{cool,min}$ and $T_{cool,max}$. Only the ambient temperature is varied outside of the coolant temperature limits.

When performing the test, the as-installed position of the component in the vehicle must be recreated.

11.8.3 Requirement

The DUT must be fully functional before, during, and after the test, and all parameters must be within the specifications. This is verified by means of continuous parameter monitoring and a P-03 Parameter test (large) as per section 4.7.3.

11.9 K-09 Damp heat, cyclic (with frost)

11.9.1 Purpose

This test simulates the thermal loading (including frost) of the component by cyclic temperature changes with high humidity during vehicle operation. It is meant to verify the resistance of the components to damp heat.

11.9.2 Test

The test is carried out as per DIN EN 60068-2-38 with the following parameters:

Table 70: Test parameters for K-09 Damp heat, cyclic (with frost)

Operating mode of the DUT	40 min "Operation _{min} " and 10 min "Operation _{max} ," intermittently. For components with excessive self-heating, the contractor and the purchaser must agree on whether the duration in operating mode "Operation _{max} " is to be shortened to the duration required to test the overall functionality of the component. In this case, the cycle duration of 50 min must remain in place.
Total test duration	240 h
Number of cycles	10
Test cycle sequence	The first five cycles must be carried out with a cold phase and the remaining cycles must be carried out without a cold phase.
Number of DUTs	6

If a coolant circuit is present, the coolant temperature must track the respective test temperature to the limits $T_{cool,min}$ and $T_{cool,max}$. Only the ambient temperature is varied outside of the coolant temperature limits.

When performing the test, the as-installed position of the component in the vehicle must be recreated.

11.9.3 Requirement

The DUT must be fully functional before, during, and after the test, and all parameters must be within the specifications. This is verified by means of continuous parameter monitoring and a P-03 Parameter test (large) as per section 4.7.3.

11.10 K-10 Water protection – IPX0 to IPX6K

11.10.1 Purpose

This test simulates the load on the component when exposed to water. It is meant to verify the function of the component, e.g., when exposed to condensed water, rain, or splash water.

11.10.2 Test

The test is carried out as per ISO 20653 with the following parameters:

Table 71: Test parameters for K-10 Water protection – IPX0 to IPX6K

Operating mode of the DUT	1 min "Operation _{min} " and 1 min "Operation _{max} ," intermittently
Required degree of protection	As defined in the Performance Specification
Number of DUTs	6

When performing the test, the as-installed position of the component in the vehicle must be recreated.

11.10.3 Requirement

The required degree of protection defined in the Performance Specification as per ISO 20653 must be achieved.

The ingress of water is not permissible. The DUT must not be opened until after completion of the entire test sequence.

The DUT must be fully functional before, during, and after the test, and all parameters must be within the specifications. This is verified by means of continuous parameter monitoring and a P-02 Parameter test (small) as per section 4.7.2.

11.11 K-11 High-pressure cleaning/pressure washing

11.11.1 Purpose

This test simulates the load on the component when subjected to water during vehicle cleaning.

It is meant to verify the function of the component when exposed to high-pressure cleaning/pressure washing.

11.11.2 Test

The test is carried out as per ISO 20653 with the following parameters:

Table 72: Test parameters

Operating mode of the DUT	Off-grid parking _{min}
Required degree of protection	IP X9K
Water pressure	The minimum pressure of the pressure washer is 10 000 kPa (100 bar), measured directly at the nozzle.
Water temperature	80 °C
Procedure	The DUT must be exposed to the water jet from every spatial direction freely accessible on the vehicle.
Number of DUTs	6

When performing the test, the as-installed position of the component in the vehicle must be recreated.

11.11.3 Requirement

Degree of protection IP X9K as per ISO 20653 must be achieved.

The ingress of water is not permissible. The DUT must not be opened until after the entire test sequence has been completed as per the test sequence plan (section 9.2).

The DUT must be fully functional before, during, and after the test, and all parameters must be within the specifications. This is verified by means of continuous parameter monitoring and a P-02 Parameter test (small) as per section 4.7.2.

11.12 K-12 Thermal shock with splash water

11.12.1 Purpose

This test simulates the load on the component when exposed to splash water when driving through puddles.

It is meant to verify the function of the component when subjected to abrupt cooling by water.

11.12.2 Test

Table 73: Test parameters for K-12 Thermal shock with splash water

Operating mode of the DUT	"Driving _{min} " and "Driving _{max} " intermittently (see Figure 37)
Test procedure	The DUT is heated up to test temperature. The DUT is then cyclically exposed to splash water as per Figure 37. The DUT must be exposed to splash water over its entire breadth.
Cycle duration	30 min
Test temperature	T _{max}
Test medium for splashing	Tap water with 3 weight percent fine Arizona dust as per ISO 12103-1 Permanent mixing must be ensured.
Splash water temperature	0 to +4 °C
Splash nozzle	See Figure 38.
Splash duration	3 s
Water discharge	3 to 4 liters per splash/nozzle
Distance between nozzle and DUT	300 to 350 mm
Number of cycles	100
Number of DUTs	6

When performing the test, the as-installed position of the component in the vehicle must be recreated.

The test setup (as-installed position, covers, trim panels, situation during operation) must be suggested by the contractor, approved by the purchaser, and documented.

If a coolant circuit is present, the coolant temperature must track the respective test temperature up to the limit T_{cool,max}. Only the ambient temperature is varied above the coolant temperature limit.

Test setup as per Figure 39

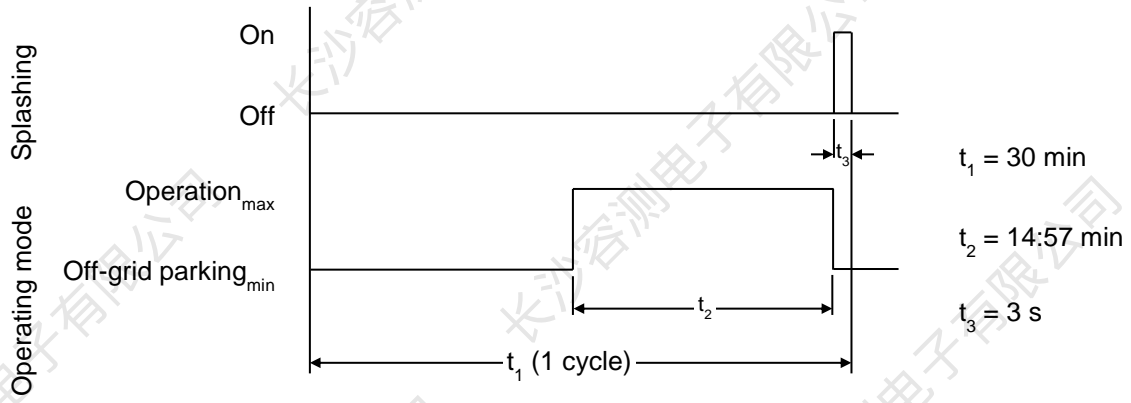
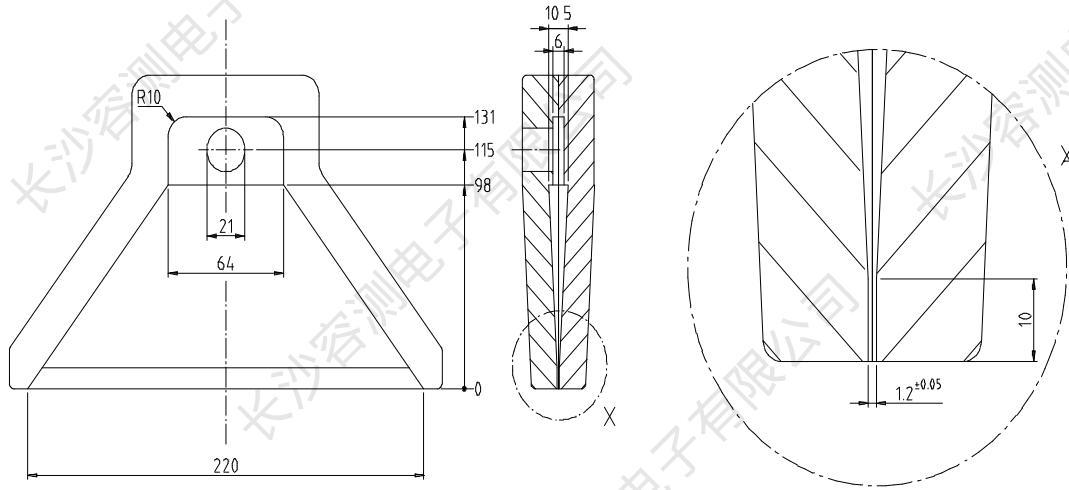

Figure 37: Splash water test – splashing times



Dimensions in mm

Figure 38: Splash water test – splash nozzle

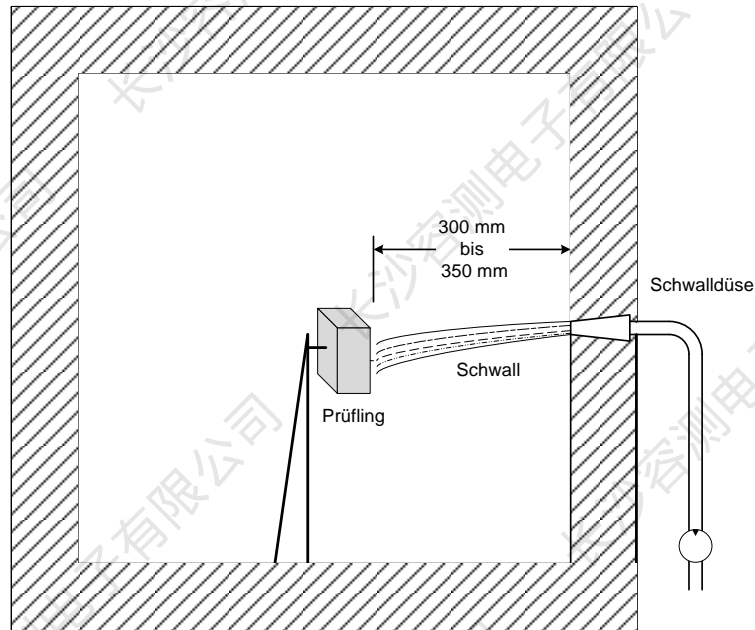

Figure 39: Splash water test setup

300 mm bis 350 mm	300 mm to 350 mm
Prüfling	DUT
Schwall	Splashing
Schwalldüse	Splash nozzle

11.12.3 Requirement

The ingress of water is not permissible. The DUT must not be opened until after completion of the entire test sequence.

The DUT must be fully functional before, during, and after the test, and all parameters must be within the specifications. This is verified by means of continuous parameter monitoring and a P-02 Parameter test (small) as per section 4.7.2.

11.13 K-13 Thermal shock – immersion

11.13.1 Purpose

This test simulates the load on the component when immersed in water. The test is meant to verify the function of the component when subjected to immediate cooling due to immersion of the heated component.

11.13.2 Test

The test is carried out as per ISO 20653 with the following parameters:

Table 74: Test parameters for K-13 Thermal shock – immersion

Operating mode of the DUT	Driving _{max}
Required degree of protection	IP X7
Test procedure	The DUT is heated up to $T_{op,max}$
	It is then hold at $T_{op,max}$ until the DUT reaches temperature stabilization (see section 4.6), plus an additional 15 min.
	The DUT is completely immersed in the test medium for ≤ 5 s.
	The DUT must be immersed so that all sides of the DUT are covered by at least 25 mm of the test medium.
Test medium	Cold water at 0 °C with a salt content of 5%
Immersion duration	5 min
Number of cycles	20
Number of DUTs	6

When performing the test, the as-installed position of the component in the vehicle must be recreated.

If a coolant circuit is present, the coolant temperature must track the respective test temperature up to the limit $T_{cool,max}$. Only the ambient temperature is varied above the coolant temperature limit.

11.13.3 Requirement

The ingress of water is not permissible. The DUT must not be opened until after the entire test sequence has been completed as per the test sequence plan (section 9.2).

The DUT must be fully functional before, during, and after the test, and all parameters must be within the specifications. This is verified by means of continuous parameter monitoring and a P-02 Parameter test (small) as per section 4.7.2.

11.14 K-14 Damp heat, constant

11.14.1 K-14 a Damp heat, constant – severity 1

11.14.1.1 Purpose

This test simulates the load on the component due to damp heat.

It is meant to verify the resistance of the component to flaw patterns caused by damp heat, e.g., corrosion, migration/dendrite growth, and swelling and degradation of plastics, sealing compounds, and potting compounds.

11.14.1.2 Test

The test is carried out as per DIN EN 60068-2-78 with the following parameters:

Table 75: Test parameters for K-14 Damp heat, constant – severity 1

Operating mode of the DUT	Off-grid parking _{min} If "On-grid parking" operating situation is relevant to the component, then operating mode "On-grid parking _{min} " must be tested instead of operating mode "Off-grid parking _{min} ."
Test temperature	40 °C
Humidity	93% relative humidity
Test duration	21 days
Number of DUTs	6

11.14.1.3 Requirement

The DUT must be fully functional before, during, and after the test, and all parameters must be within the specifications. This is verified by means of continuous parameter monitoring and a P-03 Parameter test (large) as per section 4.7.3.

In addition, a P-01 Parameter test (function check) as per section 4.7.1 must be performed every seven days.

11.14.2 K-14 b Damp heat, constant – severity 2

11.14.2.1 Purpose

This test simulates the load on the component due to damp heat during the vehicle service life in the form of an accelerated test.

It is meant to verify the quality and reliability of the component in terms of flaw patterns caused by damp heat, e.g., corrosion, migration/dendrite growth, and swelling and degradation of plastics, sealing compounds, and potting compounds.

11.14.2.2 Test

The test is carried out as per DIN EN 60068-2-78 with the following parameters:

Table 76: Test parameters for K-14 Damp heat, constant – severity 2

Operating mode of the DUT	Intermittent operation, 47 h "Off-grid parking _{min} " and 1 h "Operation _{max} ," repeating, until the end of the test duration. If "On-grid parking" operating situation is relevant to the component, then operating mode "On-grid parking _{min} " must be tested instead of operating mode "Off-grid parking _{min} ."
Test duration	As defined in the Performance Specification as per section F.1 (Lawson model)
Test temperature	65 °C
Test humidity	93% relative humidity
Number of DUTs	6

If a coolant circuit is present, the coolant temperature must track the respective test temperature up to the limit $T_{cool,max}$. Only the ambient temperature is varied above the coolant temperature limit.

Before this service life test is performed, a check must be performed as to whether the test parameters of 65 °C and 93% relative humidity exceed the physical limits of the materials being used in the components (e.g., hydrolysis of plastics) as a result of the highly accelerated nature of the test. If required, the contractor and purchaser must agree upon the adaptation of the test temperature and test humidity while increasing the test duration according to the Lawson model (e.g., to 55 °C and 93% relative humidity) so that the physical limits of the materials being used are not exceeded during the test. However, the test severity must remain in place throughout the test. The test humidity must not exceed a value of 93% relative humidity.

It must be ensured that no condensation occurs on the DUT during the test (also no localized condensation).

11.14.2.3 Deviating test for components with reduced performance at high temperatures

For components with reduced performance (e.g., reduction of LCDs' backlighting) in the event of high temperatures at or above $T_{op,max}$ ($T_{op,max} < 65$ °C), the test must not

be performed at a constant temperature of 65 °C – deviating from Table 76 – but rather with the following parameters (see Table 77).

Table 77: Test parameters for K-14 Damp heat, constant, for components with reduced performance at high temperatures

Operating mode of the DUT	Intermittent operation as per Figure 40
Test duration	As defined in the Performance Specification as per section F.1 (Lawson model) The respective ramp times between 65 °C and $T_{op, max}$ are not included in the test duration.
Test temperature	As per Figure 40 The temperature gradient must be selected such that no condensation occurs on the DUT.
Test humidity	93% relative humidity
Interval time t_1	47 h
Interval time t_2	1 h
Number of DUTs	6

If a coolant circuit is present, the coolant temperature must track the respective test temperature up to the limit $T_{cool, max}$. Only the ambient temperature is varied above the coolant temperature limit.

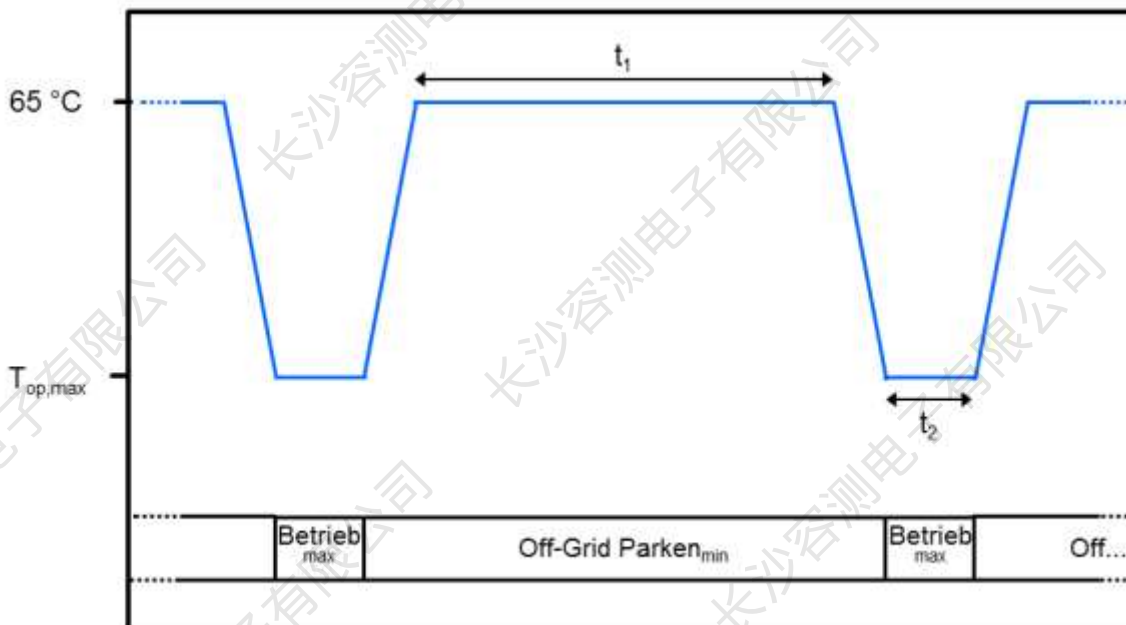

Figure 40: Temperature profile for testing of components with reduced performance at high temperatures greater than $T_{op, max}$

Betrieb _{max}	Operation _{max}
Off-Grid Parken _{min}	Off-grid parking _{min}

11.14.2.4 Requirement

The DUT must be fully functional before, during, and after the test, and all parameters must be within the specifications. This is verified by means of continuous parameter monitoring and a P-03 Parameter test (large) as per section 4.7.3.

11.15 K-15 Condensation and climatic test

11.15.1 K-15 a Condensation test with modules

11.15.1.1 Purpose

This test simulates the condensation on electronic modules in motor vehicles. It is meant to evaluate the robustness of electronic modules with respect to condensation.

11.15.1.2 Test

The test is performed with modules without a housing, with the following parameters:

Table 78: Test parameters for K-15 a Condensation test with modules

Operating mode of the DUT	Off-grid parking _{min} In addition, P-01 Parameter tests (function checks) must be performed as described in the "Test procedure" row.
Testing equipment	Climatic chamber with condensation option (specifically controlled water bath by means of which the required water quantity is converted into water vapor). The climate control is switched off during the condensation phase. The test-chamber temperature is controlled by means of the temperature-controlled water bath.
Test procedure	<ol style="list-style-type: none"> 1. The climatic chamber remains at the initial temperature for 60 min to ensure that the DUT is thermally stabilized. Then the condensation phase begins. 2. A P-01 Parameter test (function check) is performed upon every increase in water bath temperature by 10 K, in the range from 30 min after the start of the condensation phase (as per Figure 43) until 30 min before the end of the condensation phase, but only at a voltage of V_{op}. The P-01 Parameter test (function check) must be performed for max. 2 min with the lowest possible power loss. Otherwise, the DUT is heated too much and condensation is no longer possible as a result.
Test temperature	See Figure 43.
Relative humidity of test chamber	See Figure 43. The relative humidity of the test chamber must be 100% (0%, -5%) during the condensation phase.

Test duration	32.5 h (5 cycles of 6.5 h each)
Test medium	Distilled water with a maximum conductivity of 5 $\mu\text{S}/\text{cm}$
DUT position	<p>As-installed position as in the vehicle Plastic brackets must be used to maintain the as-installed position of the module in the climatic chamber.</p> <p>If the module is used in different installation positions, the DUTs must also be positioned in different installation positions in the climatic chamber.</p>
Test setup	<p>See Figure 41</p> <p>During the test, a plastic hood as per Figure 42 must be used to eliminate undesired effects in the case of different air speeds. The hood must be oriented in such a way that its slope points toward the test chamber door.</p> <p>The dimensions of the plastic hood must be adapted to the size of the test chamber.</p> <p>The distance between the plastic hood and the test chamber wall must be 10% of the test room width/depth, but at least 8 cm.</p> <p>An angle α of $\geq 12^\circ$ must be used as the roof slope of the plastic hood as per DIN EN ISO 6270-2.</p>
Test condition	<p>For the first time, the condensation test must be performed prior to the final specification of the circuit layout (hardware freeze), but already with modules manufactured under conditions similar to production, in order to optimize any discovered condensation sensitivities, e.g., by means of layout and circuit modifications.</p> <p>If the manufacturing process of the module is changed (e.g., circuit carrier, solder, flux, soldering process, layout, location, or subcomponents), the test must be repeated.</p>
Number of cycles	5
Number of DUTs	6 modules

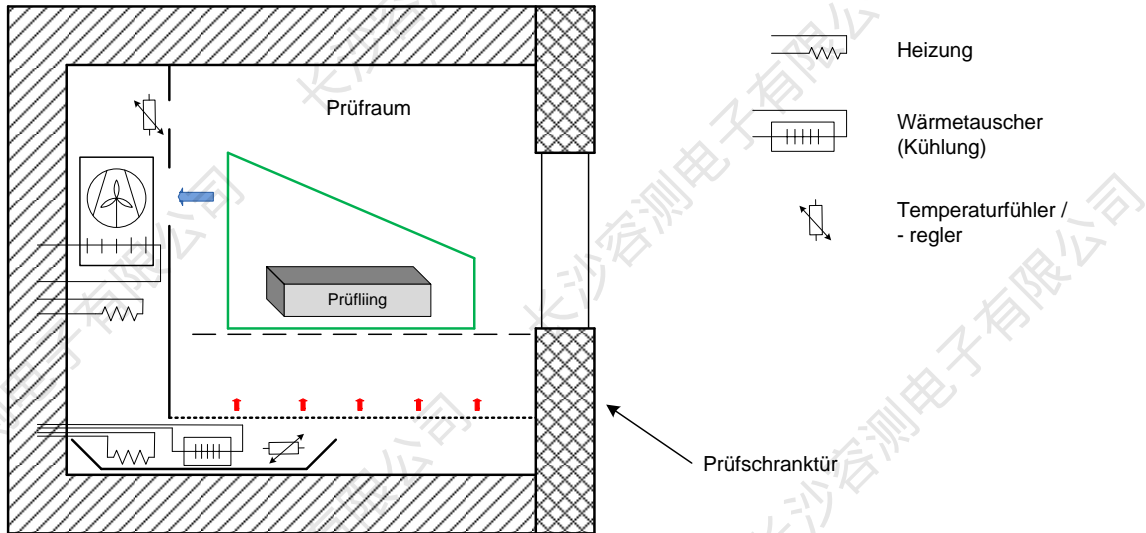

Figure 41: Test setup – K-15 a Condensation test with modules

Prüfraum	Test chamber
Prüfling	DUT
Heizung	Heating system
Wärmetauscher (Kühlung)	Heat exchanger (cooling)
Temperaturfühler / -regler	Temperature sensor/controller
Prüfschranktür	Test chamber door

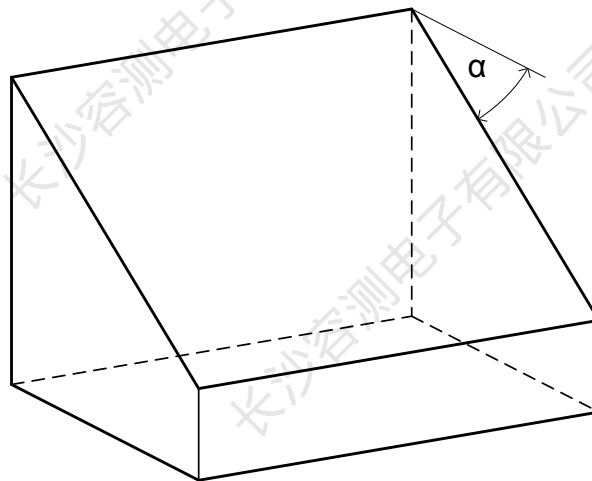
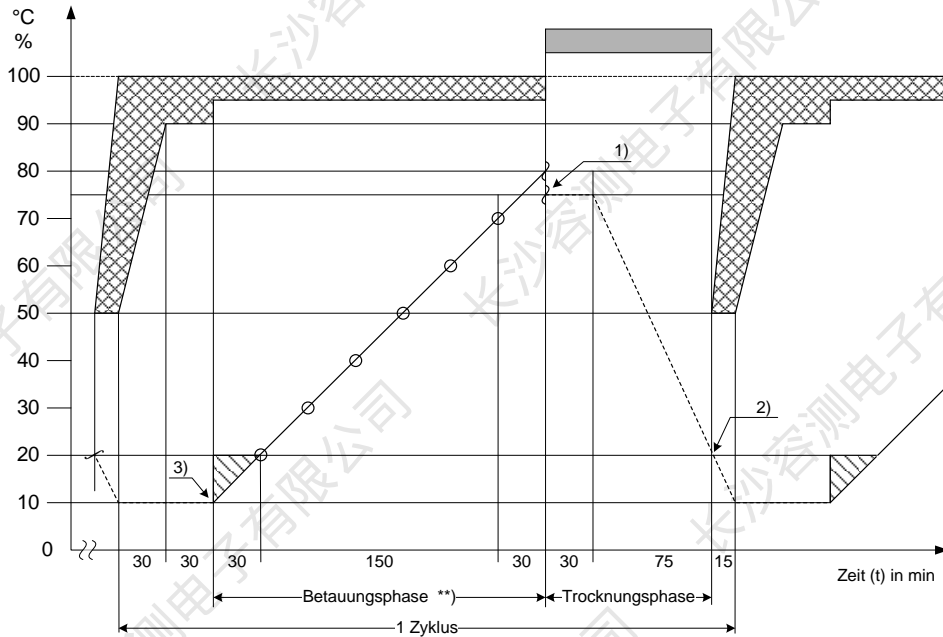

Figure 42: Plastic hood



- 1) Start der Trocknungsphase nach Erreichen von 75 °C Lufttemperatur
- 2) Prüfling muss trocken sein $F_{rel} < 50\%$
- 3) Umschaltung von Klimaregelung auf Wasserbadregelung

- Parametertest (Funktionstest) bei U_B
- Wasserbadtemperatur $\pm 1\text{ K}$
- - - Prüfraumtemperatur $\pm 3\text{ K}$

- ▨ Prüfraumfeuchte
- ▨ Wasserbadtemperatur $< 20^\circ\text{C}$
- Feuchteverlauf nicht definiert

**)) Aufzeichnung der Prüfraumfeuchte und -temperatur, Temperaturdifferenz $< 15^\circ\text{C}$

Figure 43: Sequence – K-15 a Condensation test with modules

Betauungsphase **)	Condensation phase **)
Trocknungsphase	Drying phase
Zeit (t) in min	Time (t) in min
1 Zyklus	1 cycle
1) Start der Trocknungsphase nach Erreichen von 75 °C Lufttemperatur	1) Start of the drying phase after reaching an air temperature of 75 °C
2) Prüfling muss trocken sein $F_{rel} < 50\%$	2) The DUT must be dry; $H_{rel} < 50\%$
3) Umschaltung von Klimaregelung auf Wasserbadregelung	3) Climate control is switched to water-bath control
Parametertest (Funktionstest) bei U_B	Parameter test (function check) at V_{op}
Wasserbadtemperatur $\pm 1\text{ K}$	Water bath temperature $\pm 1\text{ K}$
Prüfraumtemperatur $\pm 3\text{ K}$	Test room temperature $\pm 3\text{ K}$
**)) Aufzeichnung der Prüfraumfeuchte und -temperatur, Temperaturdifferenz $< 15^\circ\text{C}$	**)) The test-chamber humidity and temperature is recorded; temperature difference $< 15^\circ\text{C}$
Prüfraumfeuchte	Test-chamber humidity
Wasserbadtemperatur $< 20^\circ\text{C}$	Water bath temperature $< 20^\circ\text{C}$
Feuchteverlauf nicht definiert	Humidity curve not defined

11.15.1.3 Requirement

The DUT must be fully functional before, during, and after the test, and all parameters must be within the specifications. This is verified by means of continuous parameter monitoring and a P-03 Parameter test (large) as per section 4.7.3.

In addition, the module must be examined for electrochemical migration (e.g., traces of silver or tin migration) and dendrite growth.

Electrochemical migration and dendrite growth are not permissible.

Other changes to the module (e.g., corrosion, contamination) must be documented in the test report and evaluated together with the purchaser.

The following documentation must be enclosed with the test report:

1. Programming of the test chamber
2. Parameters (desired/actual) of a cycle
3. Parameters (desired/actual) of all five cycles

See Appendix G for examples.

11.15.2 K-15 b Climatic test for components with watertight housings

11.15.2.1 Purpose

This test simulates the load on the component due to damp heat during the vehicle service life in the form of an accelerated test, taking into account the protective effect of watertight housings.

It is meant to verify the quality and reliability of the component in terms of flaw patterns caused by damp heat, e.g., corrosion, migration/dendrite growth, and swelling and degradation of plastics, sealing compounds, and potting compounds.

11.15.2.2 Test

The test must be performed with complete components (device, ECU, mechatronic system, etc., with their housings).

The test must be performed as a sequence of five test blocks as per Figure 44:

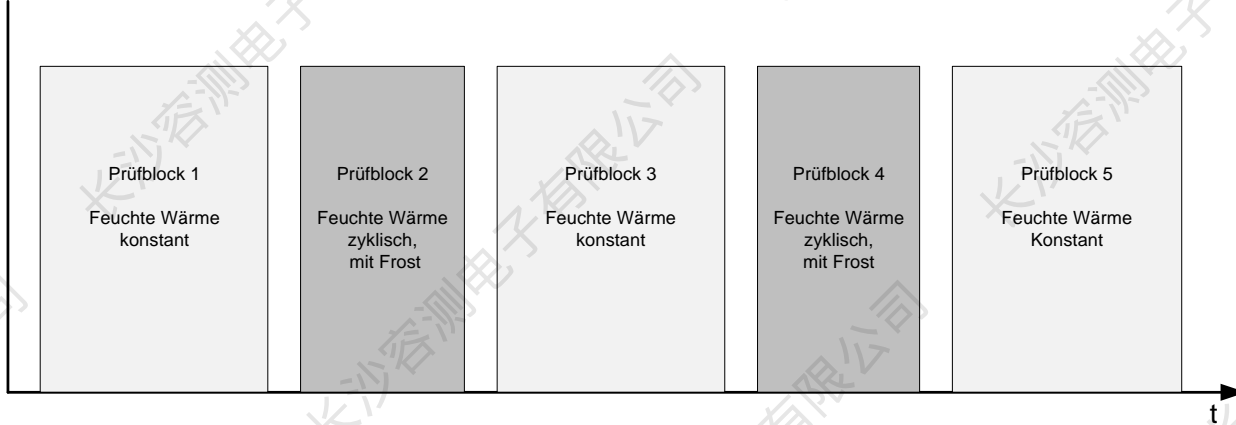

Figure 44: Sequence – K-15 b Climatic test for components with watertight housings

Prüfblock 1	Test block 1
Feuchte Wärme konstant	Damp heat, constant
Prüfblock 2	Test block 2
Feuchte Wärme zyklisch, mit Frost	Damp heat, cyclic, with frost
Prüfblock 3	Test block 3
Feuchte Wärme konstant	Damp heat, constant
Prüfblock 4	Test block 4
Feuchte Wärme zyklisch, mit Frost	Damp heat, cyclic, with frost
Prüfblock 5	Test block 5
Feuchte Wärme Konstant	Damp heat, constant

Test blocks 1, 3, and 5:

The test is carried out as per DIN EN 60068-2-78 with the following parameters:

**Table 79: Test parameters for K-15 b Climatic test for components with watertight housings
 Test blocks 1, 3, and 5**

Operating mode of the DUT	Off-grid parking _{min} A P-01 Parameter test (function check) must be performed 12 h after the start of the test block, and every 24 hours thereafter. If "On-grid parking" operating situation is relevant to the component, then operating mode "On-grid parking _{min} " must be tested instead of operating mode "Off-grid parking _{min} ."
Test duration per test block	As defined in the Performance Specification Note: The total test duration of the K-15 b test (test blocks 1 to 5) is equal to the test duration of the test K-14 b Damp heat, constant – severity 2. Of this total test duration, a test duration of 240 h each is allocated to test blocks 2 and 4. The remaining test duration is allocated equally in thirds to test blocks 1, 3, and 5: Test duration _{test block 1} = test duration _{test block 3} = test duration _{test block 5} = 1/3 (total test duration - 2 * 240 h).
Test temperature	65 °C
Test humidity	93% relative humidity
Number of DUTs	6

If a coolant circuit is present, the coolant temperature must track the respective test temperature up to the limit $T_{cool,max}$. Only the ambient temperature is varied above the coolant temperature limit.

Test blocks 2 and 4:

The test is carried out as per DIN EN 60068-2-38 with the following parameters:

**Table 80: Test parameters for K-15 b Climatic test for components with watertight housings
Test blocks 2 and 4**

Operating mode of the DUT	Off-grid parking _{min} A P-01 Parameter test (function check) must be performed 12 h after the start of the test block, and every 24 hours thereafter. If "On-grid parking" operating situation is relevant to the component, then operating mode "On-grid parking _{min} " must be tested instead of operating mode "Off-grid parking _{min} ."
Test duration per test block	240 h
Number of cycles	10
Test cycle sequence	The first five cycles must be carried out with a cold phase and the remaining cycles must be carried out without a cold phase.
Number of DUTs	6

If a coolant circuit is present, the coolant temperature must track the respective test temperature to the limits $T_{cool,min}$ and $T_{cool,max}$. Only the ambient temperature is varied outside of the coolant temperature limits.

11.15.2.3 Requirement

The DUT must be fully functional before, during, and after the test, and all parameters must be within the specifications. This is verified by means of continuous parameter monitoring and a P-03 Parameter test (large) as per section 4.7.3.

11.16 K-16 Thermal shock (without housing)

11.16.1 Purpose

This technology test does not simulate any real loading. Rather, it is meant to detect weak spots in the area of mechanical joints on modules, such as solder joints.

The test must be performed exclusively with the module of the component, without the housing and mechanical parts. Necessary supports must be set up in such a way that no additional mechanical stresses act on the module.

11.16.2 Test

The test is carried out as per DIN EN 60068-2-14 with the following parameters:

Table 81: Test parameters for K-16 Thermal shock (without housing)

Operating mode of the DUT	Assembly _{not installed}
Minimum temperature	T_{\min}
Maximum temperature	T_{\max}
Hold time at maximum and minimum temperature	15 min after complete temperature stabilization (see section 4.6)
Transfer duration	≤ 10 s
Number of cycles	300
Number of DUTs	6 modules

11.16.3 Requirement

The DUT must be fully functional before and after the test, and all parameters must meet the specifications. This is verified by means of a P-03 Parameter test (large) as per section 4.7.3.

11.17 K-17 Solar radiation

11.17.1 Purpose

This test simulates the influence of solar radiation and ultraviolet (UV) light on the component.

It is meant to verify the resistance of the component to damage caused by material fatigue, such as cracks or discolorations.

11.17.2 Test

The test is carried out as per DIN 75220 with the following parameters:

Table 82: Test parameters for K-17 Solar radiation

Operating mode of the DUT	Assembly _{not installed}
Test profiles used	The test profiles in DIN 75220 are applied, depending on the installation area of the component.
Components in the exterior	Use of the Z-OUT profile as per table 2 and table 5 of DIN 75220
Components in the interior	Use of the Z-IN1 profile as per DIN 75220
Test duration	25 days (15 days dry, 10 days humid)
Number of cycles	1
Number of DUTs	6

When performing the test, the as-installed position of the component in the vehicle must be recreated.

11.17.3 Requirement

The DUT must be fully functional before and after the test, and all parameters must meet the specifications. This is verified by means of a P-03 Parameter test (large) as per section 4.7.3.

In addition, the DUT must be visually inspected with the naked eye.

Changes or damage must be documented in the test report and evaluated together with the purchaser.

11.18 K-18 Harmful gas test

11.18.1 Purpose

This test simulates the influence of harmful gases on the component, primarily on its plug contacts and switches.

It is meant to verify the resistance of the component to flaw patterns, such as corrosion and component damage.

11.18.2 Test

The test is carried out as per DIN EN 60068-2-60, method 4, with the following parameters:

Table 83: Test parameters for K-18 Harmful gas test

Operating mode of the DUT	Assembly _{assembly}	
Temperature	T _{RT}	
Humidity	75% relative humidity	
Harmful gas concentration	SO ₂	0.2 ppm
	H ₂ S	0.01 ppm
	NO ₂	0.2 ppm
	Cl ₂	0.01 ppm
Test duration	21 days	
Number of DUTs	6	

11.18.3 Requirement

The DUT must be fully functional before and after the test, and all parameters must meet the specifications. This is verified by means of a P-03 Parameter test (large) as per section 4.7.3.

In addition, the contact resistances of switches and contacts must be measured. The measured values must be within the specifications.

12 Chemical requirements and tests

12.1 C-01 Chemical tests

12.1.1 Purpose

This test simulates the load on the component by various chemicals. It is meant to verify the resistance of the component to chemical changes on the housing and functional impairment due to chemical reactions.

12.1.2 Test

Table 84: Test parameters for chemical tests

Operating mode of the DUT	As defined in the Performance Specification
Chemicals	As defined in the Performance Specification Typical chemicals for different installation locations are indicated in Table 85.
Conditioning	Unless otherwise specified, the DUT and the chemicals must be aged in a standard atmosphere.
Test procedure	The test is performed on the basis of ISO 16750, part 5: <ol style="list-style-type: none"> 1. The chemical must be applied on the DUT at T_{RT}. Unless otherwise defined in the Performance Specification, a suitable application method as per Table 86 must be selected for each chemical. The selected application method must be documented in the test report. It must be ensured that the exterior of the DUT is adequately covered with the chemical on all materials, material interfaces (e.g., seals, material transitions), and labels being used. 2. The DUT must then be aged at the temperature indicated in Table 85 for the specified exposure time.
Number of DUTs	1 DUT per chemical. It is possible to use the DUT multiple times for several chemicals, in consultation with the purchaser.

Safety instructions and warning labels for the chemicals must be adhered to.

12.1.2.1 Chemicals

Table 85: Overview of chemicals (see also ISO 16750-5)

ID	Chemical agents	DUT temperature	Exposure time	Description/reference
1	Diesel fuel	T _{max}	22 h	EN 590
2	"Bio" diesel	T _{max}	22 h	EN 14214
3	Petrol/gasoline unleaded	T _{RT}	10 min	EN 228
4	Kerosene	T _{RT}	10 min	ASTM 1655
5	Methanol	T _{RT}	10 min	CAS 67-56-1
6	Engine oil	T _{max}	22 h	Multigrade oil SAE 0W-40, API SL/CF
7	Differential oil	T _{max}	22 h	Hypoid gear oil SAE 75W-140, API GL-5
8	Transmission fluid	T _{max}	22 h	ATF Dexron III
9	Hydraulic fluid	T _{max}	22 h	DIN 51524-3 (HVLV ISO VG 46)
10	Greases	T _{max}	22 h	DIN 51502 (KP2K-30)
11	Silicone oil	T _{max}	22 h	CAS 63148-58-3 (AP 100)
12	Battery fluid	T _{RT}	22 h	37% H ₂ SO ₄
13	Brake fluid	T _{max}	22 h	ISO 4926
14	Antifreeze fluid	T _{max}	22 h	Ethylene glycol (C ₂ H ₆ O ₂) – Water mixture 1:1
15	Urea NO _x (reduction agent)	T _{max}	22 h	ISO 22241-1
16	Cavity protection	T _{RT}	22 h	e.g., Teroson ¹ Underbody Coating Spray
17	Protective lacquer	T _{RT}	22 h	e.g., W550 (supplied by Pfinder Chemie) ¹
18	Protective lacquer remover	T _{max}	22 h	e.g., Friapol 750 (supplied by Pfinder Chemie) ¹
19	Windscreen washer fluid	T _{RT}	2 h	5% anionic tenside, deionized water
20	Vehicle washing chemicals	T _{RT}	2 h	CAS 25155-30-0 CAS 9004-82-4
21	Interior cleaner	T _{RT}	2 h	e.g., Motip ¹ Cockpit Spray
22	Glass cleaner	T _{RT}	2 h	CAS 111-76-2
23	Wheel cleaner	T _{RT}	2 h	e.g., Sonax ¹ Xtreme
24	Cold cleaning agent	T _{RT}	22 h	e.g., P3-Solvclean AK (supplied by Henkel) ¹
25	Acetone	T _{RT}	10 min	CAS 67-64-1
26	Cleaning solvent	T _{RT}	10 min	DIN 51635
27	Ammonium-containing cleaner	T _{RT}	22 h	e.g., Ajax (supplied by Henkel) ¹
28	Denatured alcohol	T _{RT}	10 min	CAS 64-17-5 (ethanol)
29	Contact spray	T _{max}	22 h	e.g., WD 40 ¹
30	Sweat/perspiration	T _{RT}	22 h	DIN 53160
31	Cosmetic products such as creams	T _{RT}	22 h	e.g., Nivea, Kenzo ¹
32	Refreshment containing caffeine and sugar	T _{RT}	22 h	Cola
33	Runway de-icer	T _{RT}	2 h	SAE AMS 1435A
34	E85 fuel	T _{RT}	10 min	DIN 51625
	Additional agents			

¹) Example manufacturer; the exact chemicals must be agreed upon with the appropriate department

Table 86: Application methods

Code	Application method
I	Spraying
II	Brushing
III	Wiping (e.g., with a cotton cloth)
IV	Dousing
V	Brief immersion
VI	Immersion

12.1.3 Requirement

The DUT must be fully functional before and after the test, and all parameters must meet the specifications. This is verified by means of a P-03 Parameter test (large) as per section 4.7.3.

Changes to lettering and markings must be documented in the test report and agreed upon with the purchaser.

13 Service life tests

13.1 L-01 Service life test – Mechanical/hydraulic durability testing

13.1.1 Purpose

This test simulates the function/actuation cycles of the component during the vehicle service life.

It is meant to verify the quality and reliability of the component with respect to function/actuation cycles, e.g., brake actuations, seat adjustment cycles, switch/button actuations.

13.1.2 Test

Test details must be defined according to the function/actuation cycle in the Performance Specification.

Table 87: Test parameters for L-01 Service life test – Mechanical/hydraulic durability testing

Operating mode of the DUT	"Operation _{max} " according to the function/actuation cycle
Test temperature	The function/actuation cycles must be performed at the temperatures indicated in the temperature load spectrum, the duration depending on their percentage share (see Appendix C). At least two temperature ramps as per Appendix C must be run through.
Number of function/actuation cycles	As defined in the Performance Specification
Number of DUTs	6

When performing the test, the as-installed position of the component in the vehicle must be recreated.

If a coolant circuit is present, the coolant temperature must track the respective test temperature to the limits $T_{cool,min}$ and $T_{cool,max}$. Only the ambient temperature is varied outside of the coolant temperature limits.

13.1.3 Requirement

The DUT must be fully functional before, during, and after the test. All key parameters must be within the specifications. This must be verified by continuous parameter monitoring. Intermediate measurements at 25%, 50%, and 75% of the test duration and parameter tests as per the test sequence plan must only be carried out if the component's functions cannot be adequately monitored during the test.

The intermediate measurements must be carried out as a P-03 Parameter test (large).

The data from continuous parameter monitoring must be evaluated with respect to drifts, trends, and irregular behavior or anomalies.

For components on coolant circuits:

For components with coated copper parts in the coolant path, these copper parts must be examined with a stereo microscope at 20x magnification after the test. Flaws or copper corrosion perceptible during this examination are not permissible.

13.2 L-02 Service life test – High-temperature durability testing

13.2.1 Purpose

This test simulates the thermal load on the component during electrical operation over the vehicle service life in the form of an accelerated test.

It is meant to verify the quality and reliability of the component with respect to thermally induced flaw patterns, such as diffusion, migration, and oxidation.

13.2.2 Test

13.2.2.1 Test for components without a connection to the coolant circuit, without reduced performance at high temperatures

The test is carried out as per DIN EN 60068-2-2 with the following parameters:

Table 88: Test parameters for

L-02 Service life test – High-temperature durability testing – Test for components without a connection to the coolant circuit, without reduced performance at high temperatures

Operating mode of the DUT	Intermittent, 47 h "Operation _{max} " and 1 h "Off-grid parking _{min} " In operating mode "Operation _{max} ," the component must be operated intermittently in all relevant operating modes with a high operating load. The ratio of time shares between these operating modes must correspond to the ratio of the respective partial test durations.
Test duration	For each relevant operating situation as per section 4.3, the partial test duration must be calculated as per appendix D.2 (Arrhenius model). The total test duration is the sum of all partial test durations.
Test temperature	T _{max}
Number of DUTs	6

When performing the test, the as-installed position of the component in the vehicle must be recreated.

13.2.2.2 Test for components without a connection to the coolant circuit, with reduced performance at high temperatures

For components with reduced performance (e.g., reduction of LCDs' backlighting) in the event of high temperatures at or above $T_{op,max}$, the test as per Table 89 must not be performed at a constant temperature of T_{max} , but rather with a temperature profile with the following parameters:

The test is carried out as per DIN EN 60068-2-2 with the following parameters:

Table 89: Test parameters for

L-02 Service life test – High-temperature durability testing –

Operating mode of the DUT	Intermittent as per Figure 45 In operating mode "Operation _{max} " and "Operation _{max} *,", the component must be operated intermittently in all relevant operating modes with a high operating load. The ratio of time shares between these operating modes must correspond to the ratio of the respective partial test durations.
Test duration	For each relevant operating situation as per section 10.1, the respective partial test duration must be calculated as per appendix D.4 (Arrhenius model). The total test duration is the sum of all partial test durations. The respective ramp times between T_{max} and $T_{op,max}$ are not included in the test duration.
Test temperature	As per Figure 45
Interval time t_1	Must be calculated as per appendix D.4 and defined in the Performance Specification
Interval time t_2	Must be calculated as per appendix D.4 and defined in the Performance Specification
Number of DUTs	6

When performing the test, the as-installed position of the component in the vehicle must be recreated.

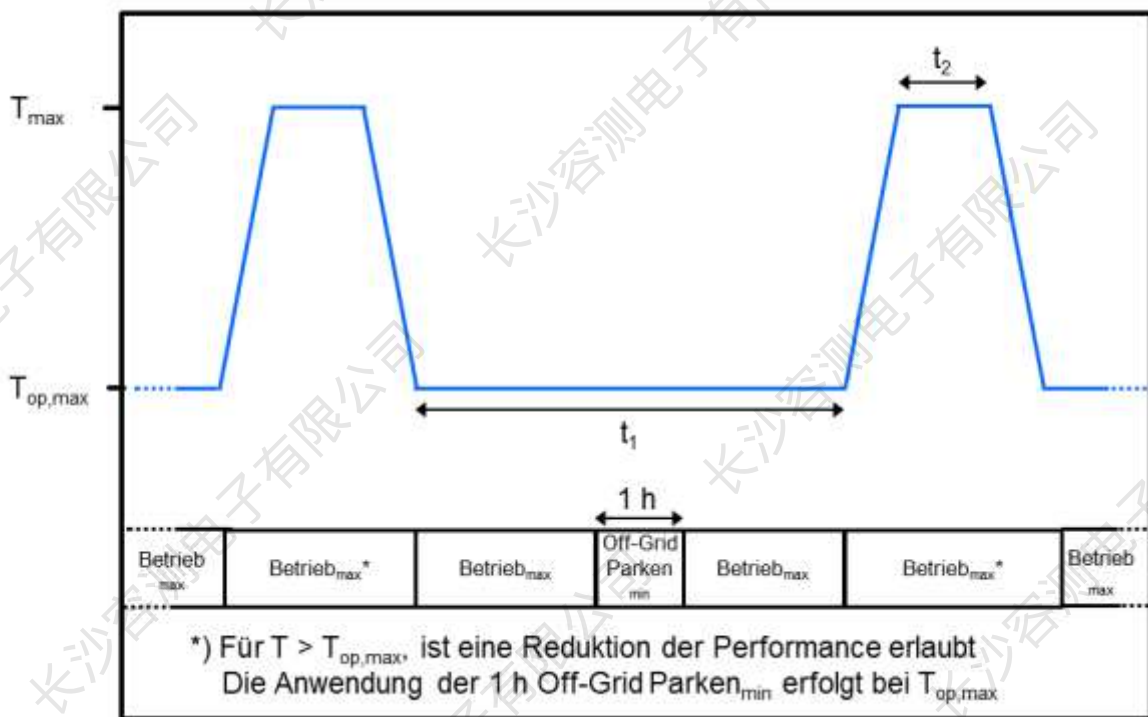

Figure 45: Temperature profile for testing of components with reduced performance at high temperatures

Betrieb_{max} Operation_{max}

Off-Grid Parken _{min}	Off-grid parking _{min}
*) Für $T > T_{op,max}$, ist eine Reduktion der Performance erlaubt Die Anwendung der 1 h Off-Grid Parken _{min} erfolgt bei $T_{op,max}$	*) For $T > T_{op,max}$, a reduction in performance is permitted. 1 h of "Off-grid parking _{min} " is applied at $T_{op,max}$

13.2.2.3 Test for components with a connection to a coolant circuit

The test is carried out as per DIN EN 60068-2-2 with the following parameters:

Table 90: Test parameters for

L-02 Service life test – High-temperature durability testing – Test for components with a connection to a coolant circuit

Operating mode of the DUT	Intermittent, 47 h "Operation _{max} " and 1 h "Off-grid parking _{min} " In operating mode "Operation _{max} ," the component must be operated intermittently in all relevant operating modes with a high operating load. The ratio of time shares between these operating modes must correspond to the ratio of the respective partial test durations.
Test duration	For each relevant operating situation as per section 4.3, the partial test duration must be calculated as per appendix D.6 (Arrhenius model). The total test duration is the sum of all partial test durations.
Test temperature (ambient)	As per appendix D.6 (Arrhenius model to be used for components on coolant circuits)
Test temperature (coolant)	As per appendix D.6 (Arrhenius model to be used for components on coolant circuits)
Number of DUTs	6

When performing the test, the as-installed position of the component in the vehicle must be recreated.

13.2.3 Requirement

The DUT must be fully functional before, during, and after the test. All key parameters must be within the specifications. This must be verified by continuous parameter monitoring. Intermediate measurements at 25%, 50%, and 75% of the test duration and parameter tests as per the test sequence plan must only be carried out if the component's functions cannot be adequately monitored during the test.

The intermediate measurements must be carried out as a P-03 Parameter test (large).

The data from continuous parameter monitoring must be evaluated with respect to drifts, trends, and irregular behavior or anomalies.

For components on coolant circuits:

For components with coated copper parts in the coolant path, these copper parts must be examined with a stereo microscope at 20x magnification after the test. Flaws or copper corrosion perceptible during this examination are not permissible.

13.3 L-03 Service life test – Temperature cycle durability testing

13.3.1 Purpose

This test simulates the thermomechanical load on the component due to temperature changes during the vehicle service life in the form of an accelerated test.

It is meant to verify the quality and reliability of the component with respect to thermomechanically induced flaw patterns, such as aging and cracking in solder joints, adhesive joints, bonded joints, and welded joints, and at seals and housings.

13.3.2 Test

The test is carried out as per DIN EN 60068-2-14 with the following parameters:

13.3.2.1 Test for components without a connection to the coolant circuit, without reduced performance at low or high temperatures

Table 91: Test parameters for L-03 Service life test – Temperature cycle durability testing – Test for components without a connection to the coolant circuit, without reduced performance at low or high temperatures

Operating mode of the DUT	Intermittently, "Operation _{max} " and "Off-grid parking _{min} " as per Figure 46.
Temperature profile	As per Figure 46
Minimum test temperature	T _{min}
Maximum test temperature	T _{max}
Temperature gradient	4 °C/min If the temperature gradient cannot be realized by the test device, it can be reduced to values down to a minimum of 2 °C/min in agreement with the purchaser.
Hold times at T _{min} and T _{max}	15 min after complete temperature stabilization (see section 4.6)
Number of cycles	The total number of test cycles must be calculated, taking into account all relevant operating situations (section 4.3) as per appendix E.1 (Coffin-Manson model).
Number of DUTs	6

When performing the test, the as-installed position of the component in the vehicle must be recreated.

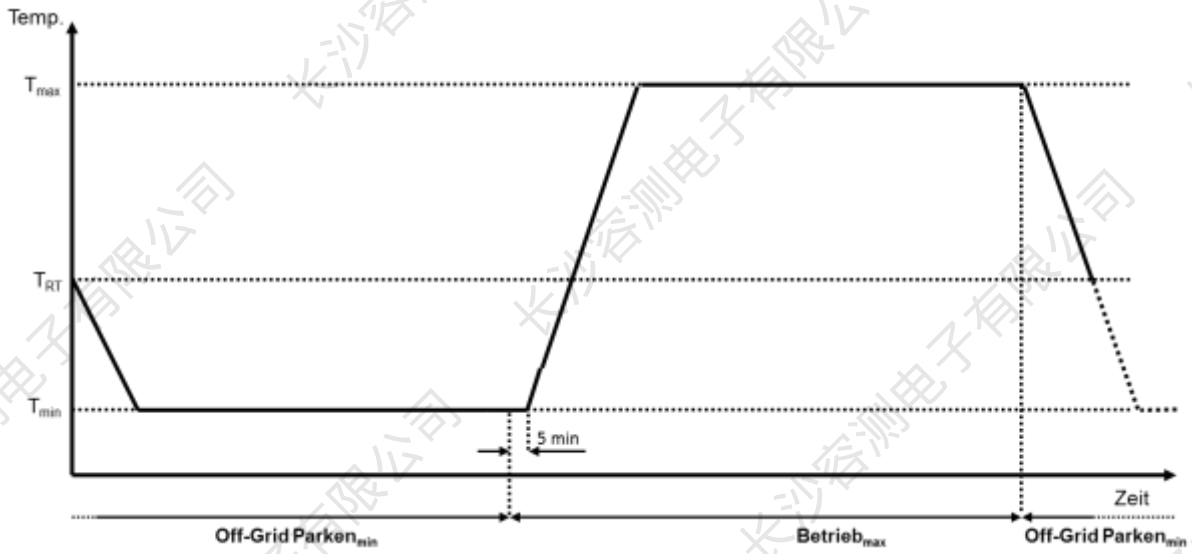

Figure 46: Temperature profile – L-03 Service life test – Temperature cycle durability testing for components without reduced performance at low or high temperatures

Off-Grid Parken _{min}	Off-grid parking _{min}
Betrieb _{max}	Operation _{max}
Zeit	Time

13.3.2.2 Test for components without a connection to the coolant circuit, with reduced performance at low or high temperatures

For components with reduced performance (e.g., reduction of LCDs' backlighting) at low or high temperatures, less than $T_{op,min}$ or greater than $T_{op,max}$, the test must be performed with the following parameters:

Table 92: Test parameters for L-03 Service life test – Temperature cycle durability testing – Test for components without a connection to the coolant circuit, with reduced performance at low or high temperatures

Operating mode of the DUT	Intermittent, "Off-grid parking _{min} " and "Operation _{max} " as per Figure 47
Temperature profile	As per Figure 47
Minimum test temperature	T_{min}
Maximum test temperature	T_{max}
Temperature gradient	4 °C/min
Hold times at T_{min} , T_{max} , $T_{op,min}$, and $T_{op,max}$	15 min after complete temperature stabilization (see section 4.6)
Number of cycles	The total number of test cycles must be calculated, taking into account all relevant operating situations (section 4.3) as per appendix D.3 (Coffin-Manson model).
Number of DUTs	6

When performing the test, the as-installed position of the component in the vehicle must be recreated.

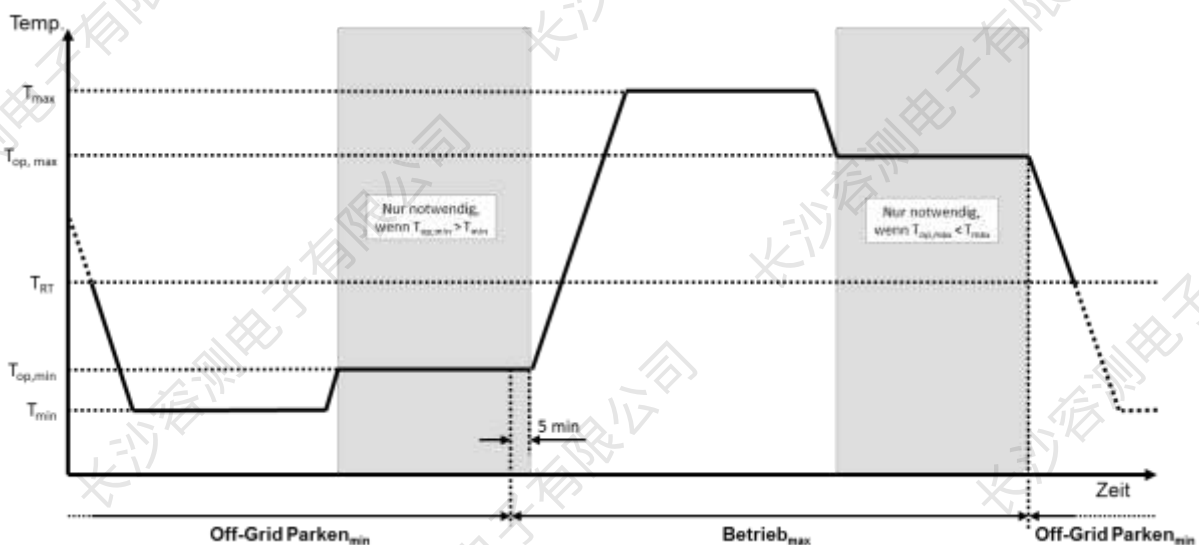

Figure 47: Temperature profile – Test for components with reduced performance at low or high temperatures

Off-Grid Parken _{min}	Off-grid parking _{min}
Betrieb _{max}	Operation _{max}
Zeit	Time
Nur notwendig, wenn $T_{op,min} > T_{min}$	Only necessary if $T_{op,min} > T_{min}$
Nur notwendig, wenn $T_{op,max} < T_{max}$	Only necessary if $T_{op,max} < T_{max}$

13.3.2.3 Test for components on the coolant circuit

For components on coolant circuits, the test must be performed with the following parameters:

Table 93: Test parameters for L-03 Service life test – Temperature cycle durability testing – Test for components on the coolant circuit

Operating mode of the DUT	Intermittent, "Off-grid parking _{min} " and "Operation _{max} " as per Figure 46 and Figure 47, respectively
Temperature profile	As per Figure 46 and Figure 47, respectively
Minimum test temperature	T_{min} and $T_{cool,min}$
Maximum test temperature	T_{max} and $T_{cool,max}$
Temperature gradient	4 °C/min
Hold times at T_{min} , T_{max} , $T_{op,min}$, and $T_{op,max}$	15 min after complete temperature stabilization (see section 4.6)
Number of cycles	The total number of test cycles must be calculated, taking into account all relevant operating situations (section 4.3) as per appendix D.5 (Coffin-Manson model to be used for components on coolant circuits).
Number of DUTs	6

When performing the test, the as-installed position of the component in the vehicle must be recreated.

13.3.3 Requirement

The DUT must be fully functional before, during, and after the test. All key parameters must be within the specifications. This must be verified by continuous parameter monitoring. Intermediate measurements at 25%, 50%, and 75% of the test duration and parameter tests as per the test sequence plan must only be carried out if the component's functions cannot be adequately monitored during the test.

The intermediate measurements must be carried out as a P-03 Parameter test (large).

The data from continuous parameter monitoring must be evaluated with respect to drifts, trends, and irregular behavior or anomalies.

For components on coolant circuits:

For components with coated copper parts in the coolant path, these copper parts must be examined with a stereo microscope at 20x magnification after the test. Flaws or copper corrosion perceptible during this examination are not permissible.

Appendix A (normative)

Test sequence

A.1 Test sequence plan

A component-specific test sequence plan must be defined in the Performance Specification.

The tests that are not required for a component as per the test selection table must be crossed out from the test sequence plan.

If a component-specific adaptation of the test sequence is required, the test sequence plan may be adapted.

All components are tested with new, original contact systems.

Original connectors/cables must be connected to the DUT before the start of the testing. Only after all tests required for the respective components have been performed can the connectors/cables be disconnected for physical analysis of the component. This requirement does not apply to tests with operating mode "Assembly_{not installed}".

The wiring harness used with the contact system must be designed in such a way that the wiring harness extends out of the test chamber without any additional intermediate connections.

A.2 Sequence tests

If the DUTs are not damaged from the M-01 "Free fall" test, two DUTs must be used for further sequence testing. Otherwise, the spare DUTs must be used.

All components must be tested with the original connector or adapter starting from the M-01 "Free fall" test.

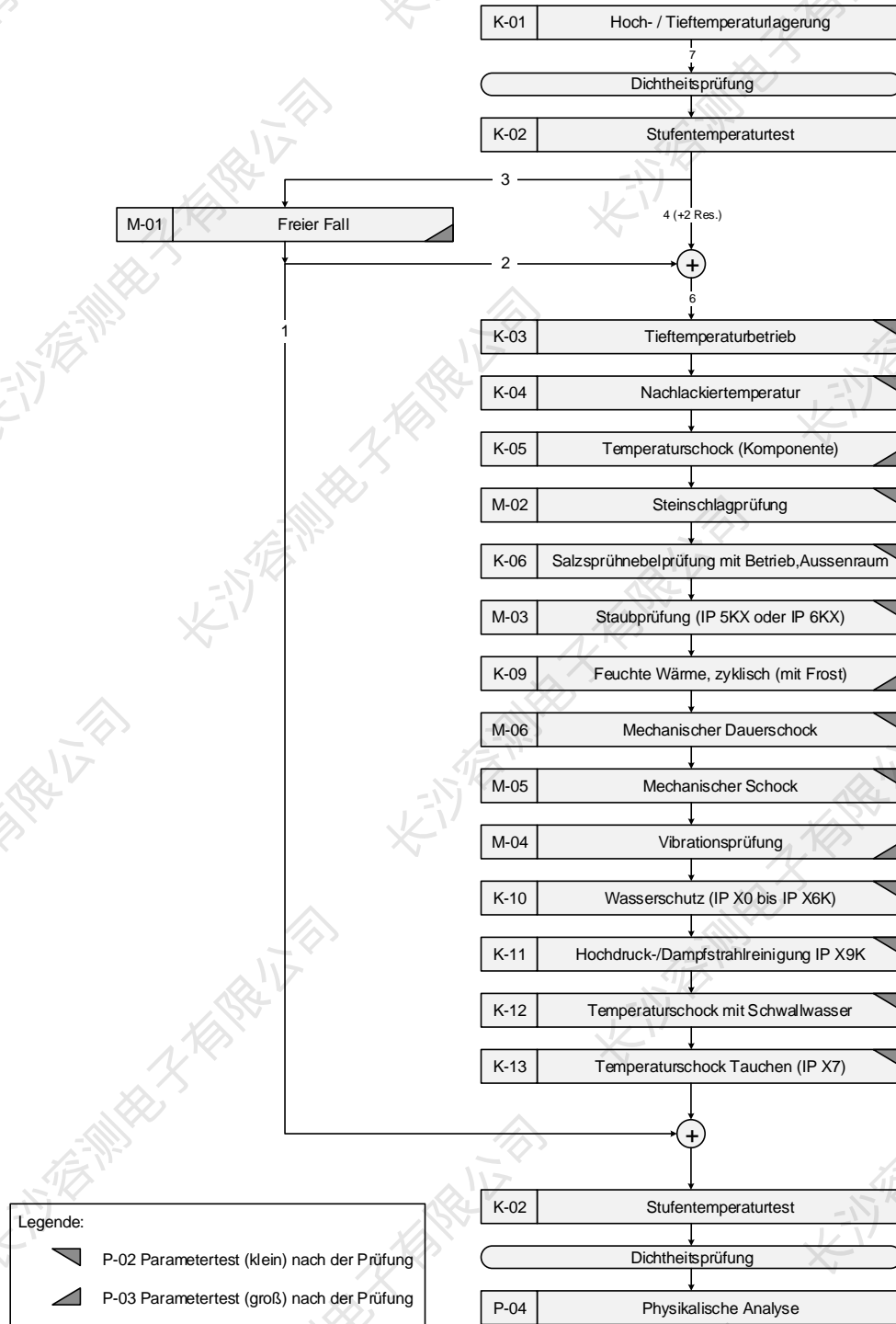

Figure 48: Test sequence plan – Sequence

K-01	K-01
Hoch- / Tieftemperaturlagerung	High/low-temperature aging
Dichtheitsprüfung	Leak tightness test
Stufentemperaturtest	Incremental temperature test
4 (+2 Res.)	4 (+2 spare DUTs)
M-01	M-01
Freier Fall	Free fall
Tieftemperaturbetrieb	Low-temperature operation
Nachlackiertemperatur	Repainting temperature
Temperaturschock (Komponente)	Thermal shock (component)
Steinschlagprüfung	Stone impact test
Salzsprühnebelprüfung mit Betrieb, Aussenraum	Salt spray test with operation, exterior
Staubprüfung (IP 5KX oder IP 6KX)	Dust test (IP 5KX or IP 6KX)
Feuchte Wärme, zyklisch (mit Frost)	Damp heat, cyclic (with frost)
Mechanischer Dauerschock	Continuous mechanical shock
Mechanischer Schock	Mechanical shock
Vibrationsprüfung	Vibration test
Wasserschutz (IP X0 bis IP X6K)	Water protection (IP X0 to IP X6K)
Hochdruck-/Dampfstrahlreinigung IP X9K	High-pressure cleaning/pressure washing IP X9K
Temperaturschock mit Schwallwasser	Thermal shock with splash water
Temperaturschock Tauchen (IP X7)	Thermal shock – immersion (IP X7)
Stufentemperaturtest	Incremental temperature test
Dichtheitsprüfung	Leak tightness test
Physikalische Analyse	Physical analysis
P-04	P-04
Legende:	Legend:
P-02 Parametertest (klein) nach der Prüfung	P-02 Parameter test (small) after the test
P-03 Parametertest (groß) nach der Prüfung	P-03 Parameter test (large) after the test

A.3 Tests outside of the sequence (parallel tests)

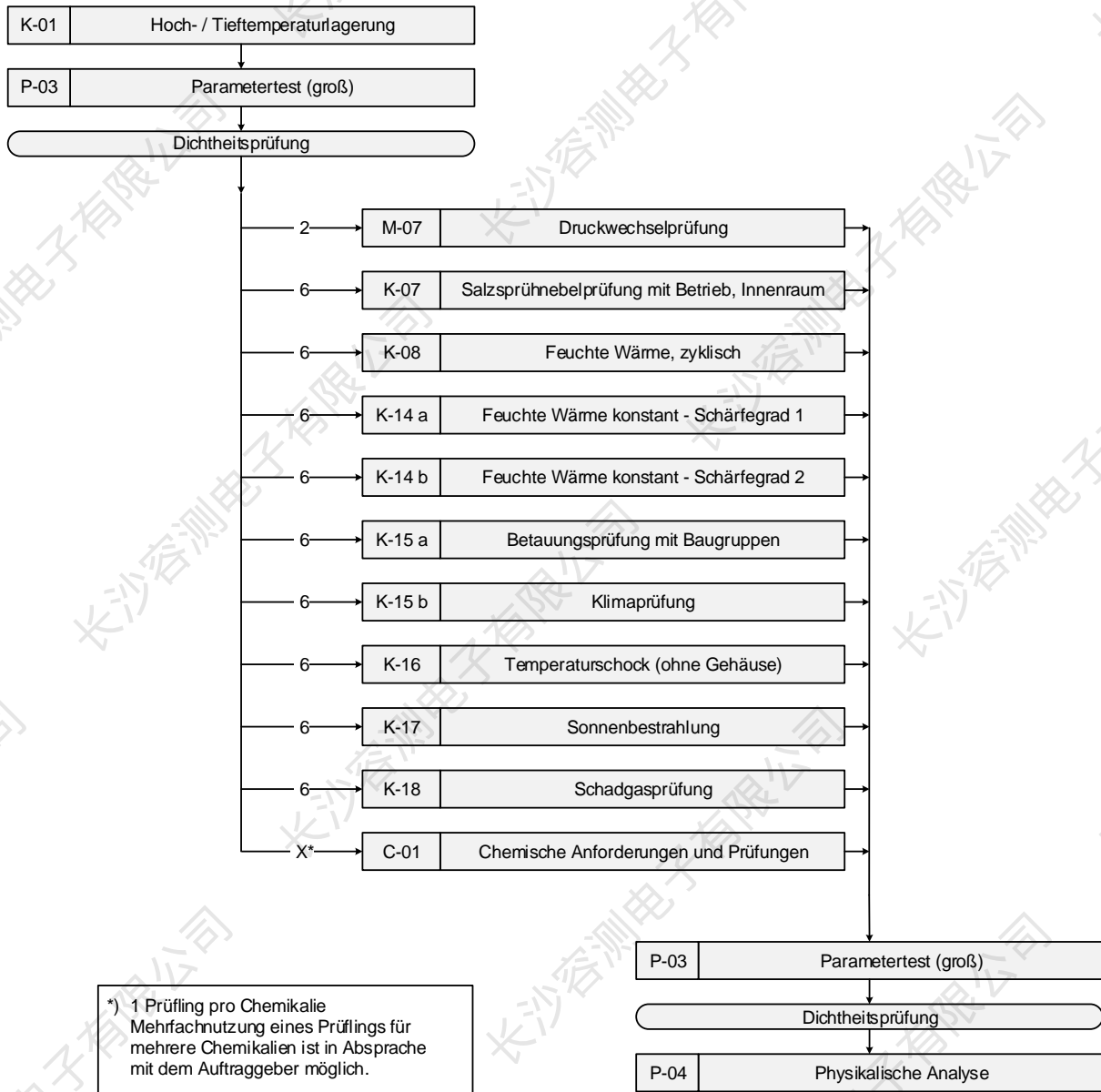

Figure 49: Test sequence plan – Parallel tests

K-01	K-01
Hoch- / Tieftemperaturlagerung	High/low-temperature aging
P-03	P-03
Parametertest (groß)	Parameter test (large)
Dichtheitsprüfung	Leak tightness test
M-07	M-07
Druckwechselprüfung	Pressure pulsation test
Salzsprühnebelprüfung mit Betrieb, Innenraum	Salt spray test with operation, interior
Feuchte Wärme, zyklisch	Damp heat, cyclic
Feuchte Wärme konstant - Schärfegrad 1	Damp heat, constant – severity 1
Feuchte Wärme konstant - Schärfegrad 2	Damp heat, constant – severity 2
Betauungsprüfung mit Baugruppen	Condensation test with modules
Klimaprüfung	Climatic test
Temperaturschock (ohne Gehäuse)	Thermal shock (without housing)
Sonnenbestrahlung	Solar radiation
Schadgasprüfung	Harmful gas test
C-01	C-01
Chemische Anforderungen und Prüfungen	Chemical requirements and tests

Parametertest (groß)	Parameter test (large)
Dichtheitsprüfung	Leak tightness test
Physikalische Analyse	Physical analysis
*) 1 Prüfling pro Chemikalie Mehrfachnutzung eines Prüflings für mehrere Chemikalien ist in Absprache mit dem Auftraggeber möglich.	*) 1 DUT per chemical; it is possible to use the DUT multiple times for several chemicals, in consultation with the purchaser

A.4 Service life tests

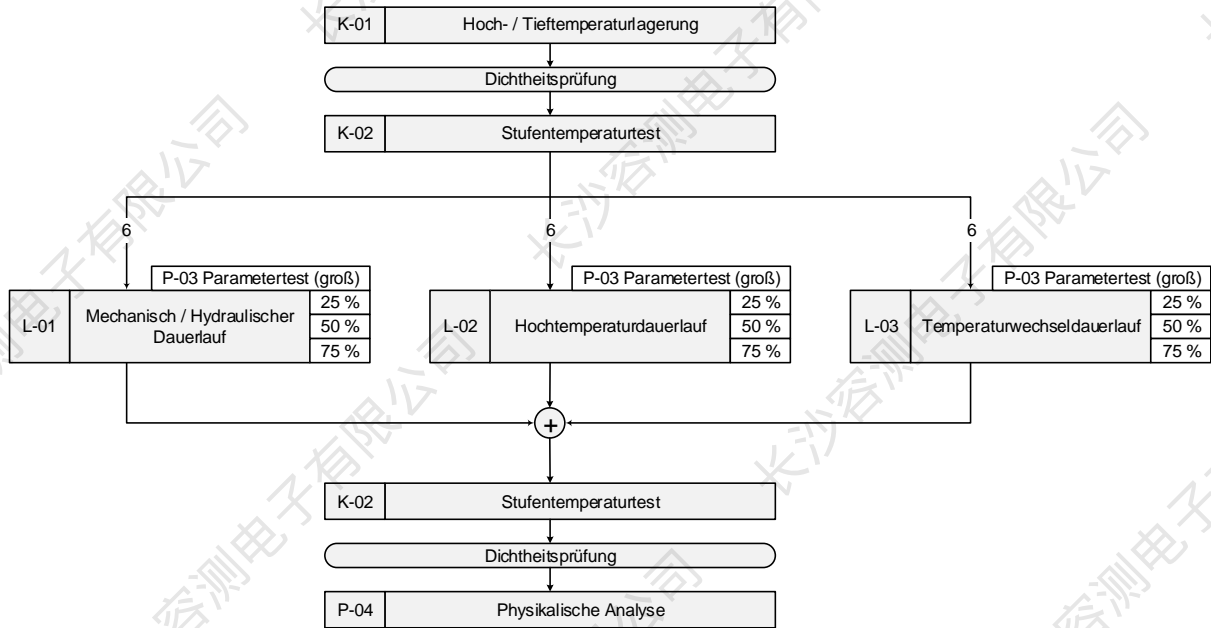

Figure 50: Test sequence plan – Service life

K-01	Hoch- / Tieftemperaturlagerung	K-01	High/low-temperature aging
	Dichtheitsprüfung		Leak tightness test
K-02	Stufentemperaturtest	K-02	Incremental temperature test
P-03	Parametertest (groß)	P-03	Parameter test (large)
L-01	Mechanisch / Hydraulischer Dauerlauf	L-01	Mechanical/hydraulic durability testing
	Hochtemperaturdauerlauf		High-temperature durability testing
	Temperaturwechseldauerlauf		Temperature cycle durability testing
K-02	Stufentemperaturtest	K-02	Incremental temperature test
	Dichtheitsprüfung		Leak tightness test
P-04	Physikalische Analyse	P-04	Physical analysis

Appendix B (normative)

Typical temperature load spectra for different installation areas

Table 94: Overview of installation areas, typical spectra, and temperature rises

Installation area of the component	Spectrum no.	Temperature rise in K
Vehicle interior, without special requirement	1	36
Body-mounted, without special requirements	1	36
Vehicle interior, exposed to solar radiation	2	46
Body-mounted, roof	2	46
Engine compartment, but not on the engine	3	60
On the radiator	3	60
Engine-mounted	4	75
Transmission-mounted	4	75

B.1 Temperature load spectrum 1

Table 95: Temperature load spectrum 1

Temperature in °C	Distribution in %
-40	6
23	20
40	65
75	8
80	1

B.2 Temperature load spectrum 2

Table 96: Temperature load spectrum 2

Temperature in °C	Distribution in %
-40	6
23	20
50	65
100	8
105	1

B.3 Temperature load spectrum 3

Table 97: Temperature load spectrum 3

Temperature in °C	Distribution in %
-40	6
23	20
65	65
115	8
120	1

B.4 Temperature load spectrum 4

Table 98: Temperature load spectrum 4

Temperature in °C	Distribution in %
-40	6
23	20
85	65
135	8
140	1

Appendix C(normative)

Calculation for the performance of the "Mechanical/hydraulic durability testing" service life test

C.1 Calculation

The temperature load spectrum being applied is used to calculate the number of mechanical/hydraulic function/actuation cycles to be completed during testing.

Table 99: Temperature load spectrum

Temperature in °C	Distribution in %
$T_{\text{field, 1}}$	p_1
$T_{\text{field, 2}}$	p_2
$T_{\text{field, 3}}$	p_3
...	...
$T_{\text{field, n}}$	p_n

The mechanical/hydraulic function/actuation cycles to be tested are distributed to each temperature, $T_{\text{field, 1}} \dots T_{\text{field, n}}$, from the temperature load spectrum being applied, using the following equation.

$$n_{T_{\text{field, i}}} = n_{\text{Total}} * p_i \quad (1)$$

The mechanical/hydraulic function/actuation cycles must be tested as per appendix C.2, Figure 51: Temperature curve for mechanical/hydraulic durability testing. At least 2 temperature ramps must be carried out. For this, equation (1) must be expanded as follows:

$$n_{T_{\text{field, i}}} = \frac{n_{\text{Total}} * p_i}{\text{temperature ramps}} \quad (2)$$

where:

- $n_{T_{\text{field, i}}}$ Number of mechanical/hydraulic function/actuation cycles for temperature increment $T_{\text{field, i}}$
- n_{total} Number of mechanical/hydraulic function/actuation cycles to be tested
- p_i Percentage share of the mechanical/hydraulic function /actuation cycles with which the component is operated in the field at temperature $T_{\text{field, i}}$
- temperature ramps Number of temperature ramps At least two temperature ramps must be carried out.

The total test duration is yielded from the following equations:

$$t_{\text{test_T}_{\text{field},i}} = n_{\text{T}_{\text{field},i}} * t_{\text{Cycle}} \quad (3)$$

$$t_{\text{test_total}} = (t_{\text{test_T}_{\text{field},1}} + \dots + t_{\text{test_T}_{\text{field},n}} + \text{temperature re-stabilization time}) * \text{Temperature ramps} \quad (4)$$

where:

t_{cycle}	Time for a mechanical/hydraulic function/actuation cycle to be tested
$t_{\text{test_T}_{\text{field},i}}$	Test duration for temperature value $T_{\text{field},i}$
temperature re-stabilization time	Duration for temperature re-stabilization between the temperature values for a temperature ramp at a temperature gradient of $2 \frac{^{\circ}\text{C}}{\text{min}}$

If a coolant circuit is present, the coolant temperature must track the respective test temperature to the limits $T_{\text{cool,min}}$ and $T_{\text{cool,max}}$. Only the ambient temperature is varied outside of the coolant temperature limits.

C.2 Example calculation

For an ECU with the temperature load spectrum indicated in the following table:

Table 100: Example temperature load spectrum

Temperature in °C	Distribution in %
-40	6
23	20
60	65
100	8
105	1

and

Number of function/actuation cycles 100 000

Cycle duration t_{cycle} 8 s/cycle

Temperature re-stabilization time 240 min,

the test duration for the "Mechanical/hydraulic durability testing" service life test is calculated as follows:

The percentage shares of the function/actuation cycles of the component for all temperatures (see table XX) of the temperature load spectrum indicated above are calculated using equation (1).

$$\begin{aligned}
 n_{T_{\text{field},1}} &= n_{\text{total}} * p_1 = 100\,000 \text{ cycles} * 0.06 = 6\,000 \text{ cycles} \\
 n_{T_{\text{field},2}} &= n_{\text{total}} * p_2 = 100\,000 \text{ cycles} * 0.20 = 20\,000 \text{ cycles} \\
 n_{T_{\text{field},3}} &= n_{\text{total}} * p_3 = 100\,000 \text{ cycles} * 0.65 = 65\,000 \text{ cycles} \\
 n_{T_{\text{field},4}} &= n_{\text{total}} * p_4 = 100\,000 \text{ cycles} * 0.08 = 8\,000 \text{ cycles} \\
 n_{T_{\text{field},5}} &= n_{\text{total}} * p_5 = 100\,000 \text{ cycles} * 0.01 = 1\,000 \text{ cycles}
 \end{aligned}$$

The partial test durations for the respective temperatures are calculated using equation (2):

$$\begin{aligned}
 t_{\text{test_Tfield},1} &= n_{T_{\text{field},1}} * t_{\text{cycle}} = 6\,000 \text{ cycles} * 8 = 48\,000 \text{ s} \\
 t_{\text{test_Tfield},2} &= n_{T_{\text{field},2}} * t_{\text{cycle}} = 20\,000 \text{ cycles} * 8 = 160\,000 \text{ s} \\
 t_{\text{test_Tfield},3} &= n_{T_{\text{field},3}} * t_{\text{cycle}} = 65\,000 \text{ cycles} * 8 = 520\,000 \text{ s} \\
 t_{\text{test_Tfield},4} &= n_{T_{\text{field},4}} * t_{\text{cycle}} = 8\,000 \text{ cycles} * 8 = 64\,000 \text{ s} \\
 t_{\text{test_Tfield},5} &= n_{T_{\text{field},5}} * t_{\text{cycle}} = 1\,000 \text{ cycles} * 8 = 8\,000 \text{ s}
 \end{aligned}$$

The total test duration for the "Mechanical/hydraulic durability testing" service life test is calculated using equation (3):

$$t_{\text{test_total}} = 48\,000 \text{ s} + 160\,000 \text{ s} + 520\,000 \text{ s} + 64\,000 \text{ s} + 8\,000 \text{ s} + 240 \text{ min} * 60 \text{ s}$$

$$t_{\text{test_total}} = 814\,400 \text{ s} = 13\,573 \text{ min} = 226 \text{ h}$$

The total test duration for the component is $t_{\text{test_total}} = 226 \text{ h}$.

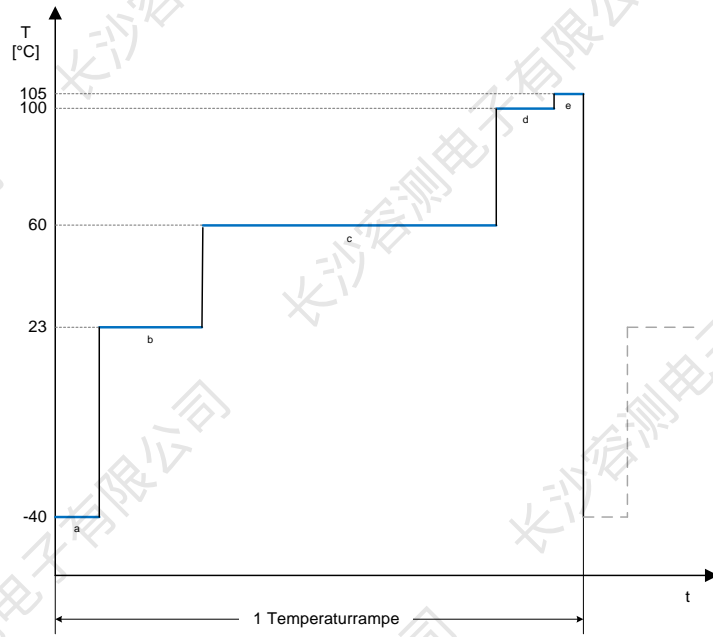

Figure 51: Temperature curve for mechanical/hydraulic durability testing

T [°C]	T [°C]
1 Temperaturrampe	1 temperature ramp
t	t

Appendix D (normative)

Calculation models for the "High-temperature durability testing" service life test

D.1 Adaptation of the test temperatures to reduce the test duration

To reduce the test duration for components that are actively operated in several operating situations, the test temperature T_{\max} (or $T_{CC, \max}$, where "CC" stands for coolant circuit) can be increased to test individual operating situations relevant to the component. For this purpose, the absolute maximum temperature T_{\max} (or $T_{CC, \max}$) can be applied as the test temperature for the operating situations relevant to the component. The component must remain fully functional here. In addition, it must be ensured that none of the parts, subcomponents, or materials belonging to the component are operated outside of their specified limits (temperature limits) in each case, taking into account any component self-heating that is generated according to the operating mode.

The test temperature can be adapted for individual or multiple operating situations relevant to the component. The test durations in each case must be calculated as per appendix C.

Details concerning an increase in the test temperature and the resulting test durations must be agreed upon between the purchaser and the contractor, and documented.

D.2 Arrhenius model

For the calculation of the test duration for the "High-temperature durability testing" service life test, the percentage temperature load spectrum according the use profile in the Performance Specification,

Table 101: Temperature load spectrum

Temperature in °C	Distribution in %
$T_{\text{field}, 1}$	p_1
$T_{\text{field}, 2}$	p_2
...	...
$T_{\text{field}, n}$	p_n

and the operating duration $t_{\text{operation}}$ of the vehicle in the field, must be used.

For each temperature from $T_{\text{field}, 1} \dots T_{\text{field}, n}$, an acceleration factor $A_{T,1} \dots A_{T,n}$ must be calculated using the following equation:

$$A_{T,i} = e^{\left[-\left(\frac{E_A}{k} \right) \left(\frac{1}{T_{\text{test}} + 273.15} - \frac{1}{T_{\text{field},i} + 273.15} \right) \right]} \quad (1)$$

where:

$A_{T,i}$ Acceleration factor of the Arrhenius model

E_A	Activation energy $E_A = 0.45 \text{ eV}$
k	Boltzmann constant ($k = 8.617 \cdot 10^{-5} \text{ eV/K}$)
T_{test}	Test temperature in °C, usually T_{max}
$T_{\text{field},i}$	Field temperature in °C, based on the temperature load spectrum according to the use profile
-273.15 °C	Absolute zero of temperature

The total test duration for high-temperature durability testing is yielded from the acceleration factors as per:

$$t_{\text{test}} = t_{\text{operation}} \cdot \sum_i \frac{p_i}{A_{T,i}} \quad (2)$$

where:

t_{test}	Test duration (hours) for the "High-temperature durability testing" service life test
$t_{\text{operation}}$	Operating duration (hours) in the field
p_i	Percentage share in operating duration during which the component is operated at temperature $T_{\text{field},i}$ in the field
$A_{T,i}$	Acceleration factor for temperature $T_{\text{field},i}$

D.3 Example Arrhenius model:

For an ECU with the temperature load spectrum indicated in the following table:

Table 102: Example spectrum

Temperature in °C	Distribution in %
-40	6
23	20
60	65
100	8
105	1

and an operating duration of 8 000 h, the test duration for the "High-temperature durability testing" service life test is calculated as follows:

The acceleration factors $A_{T,i}$ for all five temperatures (see Table 102) of the temperature load spectrum indicated above are calculated using equation (1), where $T_{\text{test}} = T_{\text{max}} = 105 \text{ °C}$.

$$A_{T,1} = 5\,369$$

$$A_{T,2} = 45.8$$

$$A_{T,3} = 6.46$$

$$A_{T,4} = 1.20$$

$$A_{T,5} = 1.00$$

The operating duration of the component is $t_{\text{operation}} = 8\,000 \text{ h}$.

The total test duration for the "High-temperature durability testing" service life test is yielded from equation (2) as:

$$t_{\text{test}} = 8\,000 \text{ hours} \cdot \left(\frac{0.06}{5369} + \frac{0.20}{45.8} + \frac{0.65}{6.46} + \frac{0.08}{1.20} + \frac{0.01}{1.00} \right) = 1\,452 \text{ hours}$$

D.4 Arrhenius model to be used for components with reduced performance at high temperatures

For the calculation of the test duration of the "High-temperature durability testing" service life test for components with reduced performance at high temperatures at or above $T_{op,max}$, the temperature load spectrum according to the use profile in the Performance Specification is divided into the two temperature ranges $T \leq T_{op,max}$ and $T > T_{op,max}$:

Table 103: Temperature load spectrum for $T \leq T_{op,max}$ with test temperature $T_{op,max}$

Temperature in °C	Distribution in %
$T_{field, 1}$	p_1
$T_{field, 2}$	p_2
...	...
$T_{field, m} (\leq T_{op,max})$	p_m

$m < n$

Table 104: Temperature load spectrum for $T_{op,max} < T \leq T_{max}$ with test temperature T_{max}

Temperature in °C	Distribution in %
$T_{field, m+1} (> T_{op,max})$	p_{m+1}
$T_{field, m+2}$	p_{m+2}
...	...
$T_{field, n}$	p_n

$m < n$

For each temperature $T_{field, 1} \dots T_{field, m} \dots T_{field, n}$, an acceleration factor $A_{T, 1} \dots A_{T, m} \dots A_{T, n}$ is calculated using equation (1), where for temperature range $T \leq T_{op,max}$ a test temperature of $T_{test} = T_{op,max}$ is assumed, and for temperature range $T > T_{op,max}$ a test temperature of $T_{test} = T_{max}$.

The required test duration $t_{op,max}$ at test temperature $T_{op,max}$ is yielded according to equation (2), where $i = 1 \dots m$.

The required test duration t_{max} at test temperature T_{max} is yielded according to equation (2), where $i = m + 1 \dots n$.

The total test duration t_{total} is the sum of $t_{op,max}$ and t_{max} .

For testing that is close to real-life conditions, the test is carried out intermittently at test temperatures $T_{op,max}$ and T_{max} (see Figure 45).

The interval duration, which is typically 48 h, is divided based on the ratio of partial test durations $t_{op,max}$ to t_{max} .

D.5 Example Arrhenius model to be used for components with reduced performance at high temperatures:

The temperature load spectrum as per Table 105 and Table 106 applies to the ECU. For an operating duration of 8 000 h, the test duration for the "High-temperature durability testing" service life test for components with reduced performance at or above $T_{op,max} = 90\text{ °C}$ is calculated as follows:

The percentage temperature distribution according to the use profile is divided into the two ranges $T \leq T_{op,max}$ and $T > T_{op,max}$:

Table 105: Example spectrum for $T \leq 90\text{ °C}$

Temperature in °C	Distribution in %
-40	6
23	20
60	65

Table 106: Example spectrum for $T > 90\text{ °C}$

Temperature in °C	Distribution in %
100	8
105	1

Using equation (1) and $T_{test} = 90\text{ °C}$, the acceleration factors $A_{T,i}$ are calculated for all temperatures $T \leq 90\text{ °C}$ (see Table 105) of the first part of the temperature load spectrum:

$$\begin{aligned} A_{T,1} &= 3\,035.79 \\ A_{T,2} &= 25.88 \\ A_{T,3} &= 3.65 \end{aligned}$$

This yields a test duration $t_{op,max}$ at a test temperature of $T_{op,max} = 90\text{ °C}$ of

$$t_{op,max}(T_{test} = 90\text{ °C}) = 8\,000\text{ hours} \cdot \left(\frac{0.06}{3035.79} + \frac{0.2}{25.88} + \frac{0.65}{3.65} \right) = 1\,487\text{ hours}$$

Using equation (1) and $T_{test} = 105\text{ °C}$, the acceleration factors $A_{T,i}$ are calculated for all temperatures $T > 90\text{ °C}$ (see Table 106) of the second part of the temperature load spectrum:

$$\begin{aligned} A_{T,4} &= 1.20 \\ A_{T,5} &= 1.00 \end{aligned}$$

This yields a test duration t_{max} at a test temperature of $T_{max} = 105\text{ °C}$ of

$$t_{max}(T_{test} = 105\text{ °C}) = 8\,000\text{ hours} \cdot \left(\frac{0.08}{1.20} + \frac{0.01}{1.00} \right) = 612\text{ hours}$$

The total test duration for the "High-temperature durability testing" service life test is yielded as the sum of the two test durations

$$t_{\text{total}} = t_{\text{op,max}} + t_{\text{max}} = 1\,487 \text{ hours} + 612 \text{ hours} = 2\,099 \text{ hours}$$

The test is performed as per Figure 45 intermittently at test temperatures $T_{\text{op,max}}$ and T_{max} with the interval times

$$t_1 = 48 \text{ h} * t_{\text{op,max}} / t_{\text{total}} = 48 \text{ h} * 1\,487 / 2\,099 = 34 \text{ h}$$

$$t_2 = 48 \text{ h} * t_{\text{max}} / t_{\text{total}} = 48 \text{ h} * 612 / 2\,099 = 14 \text{ h.}$$

D.6 Arrhenius model to be used for components on coolant circuits

For components with a connection to the coolant circuit, all relevant operating situations i (see section 4.3; " i " corresponds to the consecutive number of the situations) with their associated temperature distributions for ambient temperature and coolant circuit temperature must be taken into account.

For the "High-temperature durability testing" service life test, the test durations and test temperatures for the ambient temperature and the coolant circuit temperature must be calculated as described below for each relevant operating situation i ; the total test duration is yielded from the sum of the test durations for each relevant operating situation i .

For each relevant operating situation i , the test duration for the ambient temperature and the coolant circuit must first be calculated separately according to the Arrhenius model as per appendix D.1 or D.4, in order to calculate the test duration for operating situation i .

Because the resulting test durations $t_{\text{test, ambient}}$ and $t_{\text{test, CC}}$ usually differ, but the component can only be tested with a uniform test duration for the respective operating situation i , the test durations must be aligned between the ambient temperature and the coolant circuit temperature.

The shorter of the two test durations $t_{\text{test, ambient}}$ and $t_{\text{test, CC}}$ must be adapted to the longer test duration using the following iteration method, by dividing the test into at least two partial tests and reducing the test temperatures in all but one partial test.

Case A: $t_{\text{test, ambient}} < t_{\text{test, CC}}$

Test duration:

For $t_{\text{test, ambient}} < t_{\text{test, CC}}$, the test duration for operating situation i is

$$t_{\text{test, mode } i} = t_{\text{test, CC}}$$

Test temperature for coolant:

The test temperature must be selected according to the Arrhenius model as per appendix D.1 (usually $T_{\text{cool,max}}$).

Test temperatures for ambient temperature:

The test temperatures must be calculated iteratively according to the following algorithm on the basis of the temperature load spectrum of the ambient temperature of operating situation i being considered (Table 107).

Table 107: Temperature load spectrum for ambient temperature

Temperature in °C	Distribution in %
$T_{\text{field, 1}}$	p_1
$T_{\text{field, 2}}$	p_2
...	...
$T_{\text{field, n}}$	p_n

1. Start of iteration ($m = 0$):
The first partial test must be performed at the test temperature $T_{\text{field}, n}$ for the partial test duration $t_{\text{test}, T_{\text{field}, n}} = t_{\text{operation}} * p_n$ (where $t_{\text{operation}}$ corresponds to the operating duration in the field of operating situation i being considered, in hours).
2. First iteration ($m = 1$):
Part of the test duration for operating situation i , $t_{\text{test}, \text{situation } i}$ is covered by the 1st partial test, so a remaining test duration yet to be covered by further partial tests is yielded from

$$t_{\text{remaining}, 1} = t_{\text{test}, \text{mode } i} - t_{\text{test}, T_{\text{field}, n}}$$

In addition, the portion p_n of the temperature distribution of the ambient temperature is covered by the first partial test. Therefore, this portion p_n must be set to $p_n = 0$ for the further calculation.

To specify the test temperature for the second partial test ($m = 1$), the test temperature T_{adapted} must first be determined using the Arrhenius model as per D.1 or D.4 in such a way that a test duration equivalent to the remaining test duration $t_{\text{remaining}, 1}$ is yielded for the distribution (adapted with $p_n = 0$) of the ambient temperature.

If the adapted test temperature T_{adapted} determined in such a way is less than $T_{\text{field}, n-1}$, the second partial test must be performed at the test temperature $T_{\text{field}, n-1}$ for the test duration

$$t_{\text{test}, T_{\text{field}, n-1}} = t_{\text{operation}} * p_{n-1}$$

and at least one additional iteration step must be carried out.

If, however, the determined adapted test temperature T_{adapted} is greater than $T_{\text{field}, n-1}$, the second partial test must be performed at the test temperature T_{adapted} for the test duration

$$t_{\text{test}, T_{\text{field}, n-1}} = t_{\text{remaining}, 1}$$

and an additional iteration step does not have to be carried out (end of iteration).

3. Additional iterations ($m = 2, 3, \dots$)
A part of the test duration for operating situation i $t_{\text{test}, \text{mode } i}$ is covered by the first m partial tests, so that a remaining test duration yet to be covered by the additional partial tests is yielded from

$$t_{\text{remaining}, m} = t_{\text{test}, \text{mode } i} - \sum_{k=0}^{m-1} t_{\text{test}, T_{\text{field}, n-k}}$$

In addition, the portions p_{n-k} with $k = 0, 1, \dots, (m - 1)$ of the temperature distribution of the ambient temperature are covered by the first m partial tests. Therefore, these portions p_{n-k} must be set to $p_{n-k} = 0$ for the further calculation. To specify the test temperature for the $(m + 1)$ th partial test, the test temperature T_{adapted} must first be determined using the Arrhenius model as per D.1 or D.4 in such a way that a test duration equivalent to the remaining test duration $t_{\text{remaining}, m}$ is yielded for the distribution (adapted with $p_{n-k} = 0$) of the ambient temperature.

If the adapted test temperature T_{adapted} determined in such a way is less than $T_{\text{field}, n-m}$, the $(m + 1)$ th partial test must be performed at the test temperature $T_{\text{field}, n-m}$ for the test duration

$$t_{\text{test}, T_{\text{field}, n-m}} = t_{\text{operation}} * p_{n-m}$$

and at least one additional iteration step must be carried out.

If, however, the determined adapted test temperature T_{adapted} is greater than $T_{\text{field}, n-m}$, the $(m + 1)$ th partial test must be performed at the test temperature T_{adapted} for the test duration

$$t_{\text{test}, T_{\text{field}, n-m}} = t_{\text{remaining}, m}$$

and an additional iteration step does not have to be carried out (end of iteration).

Case B: $t_{\text{test}, \text{ambient}} > t_{\text{test}, \text{CC}}$

Test duration:

For $t_{\text{test}, \text{ambient}} > t_{\text{test}, \text{CC}}$, the test duration for operating situation i is

$$t_{\text{test}, \text{mode } i} = t_{\text{test}, \text{ambient}}$$

Test temperature (ambient):

The test temperature must be selected according to the Arrhenius model as per appendix D.1 or D.4 (generally T_{max} or T_{max} and $T_{\text{op}, \text{max}}$).

Test temperatures (coolant):

The test temperatures must be calculated iteratively using the following algorithm, on the basis of the temperature load spectrum for the coolant temperature of operating situation i being considered (Table 108).

Table 108: Temperature load spectrum for coolant temperature

Temperature in °C	Distribution in %
$T_{\text{field}, 1}$	p_1
$T_{\text{field}, 2}$	p_2
...	...
$T_{\text{field}, n}$	p_n

1. Start of iteration ($m = 0$):
The first partial test must be performed at the test temperature $T_{\text{field}, n}$ for the partial test duration $t_{\text{test}, T_{\text{field}, n}} = t_{\text{operation}} * p_n$ (where $t_{\text{operation}}$ corresponds to the operating duration in the field of operating situation i being considered, in hours).
2. First iteration ($m = 1$):
Part of the test duration for operating situation i $t_{\text{test}, \text{mode } i}$ is covered by the first partial test, so that a remaining test duration yet to be covered by the additional partial tests is yielded from

$$t_{\text{remaining}, 1} = t_{\text{test}, \text{mode } i} - t_{\text{test}, T_{\text{field}, n}}$$

In addition, the portion p_n of the temperature distribution of the coolant temperature is covered by the first partial test. Therefore, this portion p_n must be set to $p_n = 0$ for the further calculation.

To specify the test temperature for the second partial test ($m = 1$), the test temperature T_{adapted} must first be determined using the Arrhenius model as per D.1 in such a way that a test duration equivalent to the remaining test duration $t_{\text{remaining}, 1}$ is yielded for the distribution (adapted with $p_n = 0$) of the coolant temperature.

If the adapted test temperature T_{adapted} determined in such a way is less than $T_{\text{field}, n-1}$, the second partial test must be performed at the test temperature $T_{\text{field}, n-1}$ for the test duration

$$t_{\text{test}, T_{\text{field}, n-1}} = t_{\text{operation}} * p_{n-1}$$

and at least one additional iteration step must be carried out.

If, however, the determined adapted test temperature T_{adapted} is greater than $T_{\text{field}, n-1}$, the second partial test must be performed at the test temperature T_{adapted} for the test duration

$$t_{\text{test}, T_{\text{field}, n-1}} = t_{\text{remaining}, 1}$$

and an additional iteration step does not have to be carried out (end of iteration).

3. Additional iterations ($m = 2, 3, \dots$)

A part of the test duration for operating situation i $t_{\text{test}, \text{mode } i}$ is covered by the first m partial tests, so that a remaining test duration yet to be covered by the additional partial tests is yielded from

$$t_{\text{remaining}, m} = t_{\text{test}, \text{mode } i} - \sum_{k=0}^{m-1} t_{\text{test}, T_{\text{field}, n-k}}$$

In addition, the portions p_{n-k} with $k = 0, 1, \dots, (m - 1)$ of the temperature distribution of the coolant temperature are covered by the first m partial tests. Therefore, these portions p_{n-k} must be set to $p_{n-k} = 0$ for the further calculation.

To specify the test temperature for the $(m + 1)$ th partial test, the test temperature T_{adapted} must first be determined using the Arrhenius model as per D.1 in such a way that a test duration equal to the remaining test duration $t_{\text{remaining}, m}$ is yielded for the distribution (adapted with $p_{n-k} = 0$) of the coolant temperature.

If the adapted test temperature T_{adapted} determined in such a way is less than $T_{\text{field}, n-m}$, the $(m + 1)$ th partial test must be performed at the test temperature $T_{\text{field}, n-m}$ for the test duration

$$t_{\text{test}, T_{\text{field}, n-m}} = t_{\text{operation}} * p_{n-m}$$

and at least one additional iteration step must be carried out.

If, however, the determined adapted test temperature T_{adapted} is greater than $T_{\text{field}, n-m}$, the $(m + 1)$ th partial test must be performed at the test temperature T_{adapted} for the test duration

$$t_{\text{test}, T_{\text{field}, n-m}} = t_{\text{remaining}, m}$$

and an additional iteration step does not have to be carried out (end of iteration).

D.7 Example Arrhenius model to be used for components on coolant circuits

For an ECU connected to the coolant circuit, with the temperature load spectrum specified in the following tables for the ambient temperature and the coolant temperature:

Table 109: Example spectrum for ambient temperature

Temperature in °C	Distribution in %
-40	6
23	20
50	65
100	8
105	1

Table 110: Example spectrum for coolant temperature

Temperature in °C	Distribution in %
-40	6
23	20
50	65
75	8
80	1

and an operating duration of 8 000 h, the test duration for the "High-temperature durability testing" service life test is calculated as follows:

Test duration:

Calculation of the test durations for ambient temperature and coolant temperature using the Arrhenius model:

$$t_{\text{test, ambient}} = 1\,143 \text{ h}$$

$$t_{\text{test, CC}} = 2\,009 \text{ h}$$

Because $t_{\text{test, ambient}}$ is less than $t_{\text{test, CC}}$, the calculation is performed as per case A described in appendix D.6. The test duration for the ambient temperature must be adapted to $t_{\text{test, mode } i} = t_{\text{test, CC}} = 2\,009 \text{ h}$.

Test temperature for coolant:

The test temperature for the coolant is $T_{\text{CC, max}} = T_{\text{field, 5}} = 80 \text{ °C}$ as per the temperature load spectrum.

Iterative calculation of test temperatures for ambient temperature:

1. Iteration start:

The first partial test occurs at $T_{\text{field, 5}} = 105 \text{ °C}$. The test duration is $t_{\text{test, } T_{\text{field, 5}}} = t_{\text{operation}} \cdot p_5 = 8\,000 \text{ h} \cdot 1\% = 80 \text{ h}$.

2. First iteration:

A part of the test duration for operating situation i $t_{\text{test, mode } i}$ was already covered by the first partial test. Therefore, the remaining test duration must be recalculated: $t_{\text{remaining, 1}} = t_{\text{test, mode } i} - t_{\text{test, } T_{\text{field, 5}}} = 2\,009 \text{ h} - 80 \text{ h} = 1\,929 \text{ h}$.

Because the portion p_5 of the temperature distribution is covered by the first partial test, p_5 is set to $p_5 = 0$ in the temperature distribution for the further calculation by the Arrhenius model, as per the following table.

Table 111: Adapted temperature load spectrum for ambient temperature after first partial test

Temperature in °C	Distribution in %
-40	6
23	20
50	65
100	8

In order to subsequently be able to determine the test temperature for the second partial test, the test temperature T_{adapted} must be calculated using the Arrhenius model as per appendix C.1, in such a way that a test duration equivalent to the remaining test duration $t_{\text{remaining}, 1} = 1\,929$ h is yielded. Taking into account the adapted temperature distribution of the ambient temperature, the required test duration of 1 929 h is yielded at a temperature of $T_{\text{adapted}} = 89.5$ °C (exact value: 89.46 °C).

However, because T_{adapted} is less than $T_{\text{field}, 4}$ (i.e., 89.5 °C < 100 °C), the second partial test must be performed at the test temperature $T_{\text{field}, 4} = 100$ °C.

The test duration for the second partial test is $t_{\text{test}, T_{\text{field}, 4}} = t_{\text{operation}} \cdot p_4 = 8\,000$ h * 8% = 640 h.

3. Second iteration

An additional part of the test duration for operating situation i $t_{\text{test}, \text{mode } i}$ was covered by the second partial test, so the remaining test duration is yielded by:

$$t_{\text{remaining}, 2} = t_{\text{test}, \text{mode } i} - (t_{\text{test}, T_{\text{field}, 5}} + t_{\text{test}, T_{\text{field}, 4}}) = 2\,009$$
 h - 80 h - 640 h = 1 289 h.

The portions p_5 and p_4 of the temperature load spectrum for the ambient temperature were already covered by the first two partial tests.

Therefore, the portions must be set to $p_4 = p_5 = 0$ for the further iteration, as per the following table.

Table 112: Adapted temperature load spectrum for ambient temperature after first and second partial test

Temperature in °C	Distribution in %
-40	6
23	20
50	65

To be able to subsequently determine the test temperature for the third partial test, the test temperature T_{adapted} must be calculated using the Arrhenius model as per appendix D.1, in such a way that a test duration equivalent to the remaining test duration $t_{\text{remaining}, 2} = 1\,289$ h results.

Taking into account the adapted temperature distribution of the ambient

temperature, the required test duration of 1 289 h is yielded for the temperature $T_{\text{adapted}} = 82 \text{ }^{\circ}\text{C}$ (exact value: $82.17 \text{ }^{\circ}\text{C}$). Because T_{adapted} is greater than $T_{\text{field}, 3}$ (i.e., $82 \text{ }^{\circ}\text{C} > 50 \text{ }^{\circ}\text{C}$), no further iteration is necessary. Therefore, the third and final partial test is performed at $T_{\text{adapted}} = 82 \text{ }^{\circ}\text{C}$ for the test duration $t_{\text{test}, T_{\text{field}, 3}} = t_{\text{remaining}, 3} = 1\,289 \text{ h}$.

In total, testing must be performed for 80 h at $105 \text{ }^{\circ}\text{C}$ ambient temperature, for 640 h at $100 \text{ }^{\circ}\text{C}$ ambient temperature, and for 1 289 h at $82 \text{ }^{\circ}\text{C}$ ambient temperature. In this example, the coolant temperature is constant at $80 \text{ }^{\circ}\text{C}$ during the entire test duration.

Appendix E (normative)

Calculation models for the "Temperature cycle durability testing" service life test

E.1 Adaptation of the test temperatures to reduce the test cycles

To reduce the number of test cycles for components that are actively operated in several operating situations, the test temperature T_{\max} (or $T_{CC, \max}$) can be increased to test individual operating situations relevant to the component. For this purpose, the absolute maximum temperature T_{\max} (or $T_{CC, \max}$) can be applied as the upper test temperature for all operating situations relevant to the component. The component must remain fully functional here. In addition, it must be ensured that none of the parts, subcomponents, or materials belonging to the component are operated outside of their specified limits (temperature limits) in each case, taking into account any component self-heating that is generated according to the operating mode.

The test temperature can be adapted for individual or multiple operating situations relevant to the component. The required numbers of cycles must be calculated as per appendix D in each case.

Details concerning an increase in the test temperature and the resulting numbers of test cycles must be agreed upon between the purchaser and the contractor, and documented.

E.2 Coffin-Manson model

The calculation of the test duration for the "Temperature cycle durability testing" service life test is based on the average temperature change of the component in the field ΔT_{field} (see Table 94) and the number of temperature cycles during the service life in the field $N_{\text{TempCyclesField}}$.

2 temperature cycles per day are used for the number of temperature cycles in the field. This yields:

$$N_{\text{TempCyclesField}} = 2 * 365 * 15 \text{ (years)} = 10\,950 \text{ cycles}$$

Depending on the average temperature change in the field, the acceleration factor of the Coffin-Manson model is calculated as follows:

$$A_{\text{CM}} = \left(\frac{\Delta T_{\text{test}}}{\Delta T_{\text{field}}} \right)^c \quad (3)$$

where:

A_{CM} Acceleration factor of the Coffin-Manson model

ΔT_{test} Temperature difference during a test cycle ($\Delta T_{\text{test}} = T_{\max} - T_{\min}$)

ΔT_{field} Average temperature difference of the ambient temperature of the component at its point of use during the service life in the field

c Parameter of the Coffin-Manson model

A fixed value of 2.5 is used for c in this standard.

The total number of test cycles is calculated as per

$$N_{\text{test}} = \frac{N_{\text{TempCyclesField}}}{A_{\text{CM}}} \quad (4)$$

where:

N_{test} Required number of test cycles

$N_{\text{TempCyclesField}}$ Number of temperature cycles during the service life in the field

A_{CM} Acceleration factor of the Coffin-Manson model as per equation (3)

E.3 Example:

The number of test cycles (N_{test}) is calculated as follows for an ECU with $T_{\text{min}} = -40\text{ °C}$ and $T_{\text{max}} = 105\text{ °C}$, a service life of 15 years in the field, and an average temperature difference in the field of $\Delta T_{\text{field}} = 40\text{ °C}$:

1. The number of temperature cycles in the field:

$$N_{\text{TempCyclesField}} = 2 * 365 * 15 \text{ (years)} = 10\,950 \text{ cycles}$$

2. Temperature difference during a test cycle:

$$\Delta T_{\text{test}} = 105\text{ °C} - (-40\text{ °C}) = 145\text{ °C}$$

3. The acceleration factor of the Coffin-Manson model is calculated as $A_{\text{CM}} = 25.02$ using equation (3).

4. Using equation (4), this results in a number of test cycles of:

$$N_{\text{test}} = \frac{10\,950 \text{ cycles}}{25.02} = 438 \text{ cycles}$$

5. The hold time is the time until the component achieves temperature stabilization plus 15 min. Assuming that the component is thermally stabilized after 20 min, the hold time is therefore 35 min.

6. This yields the following duration for a cycle:

$$t_{\text{Zyklus}} = 2 \cdot \left(\frac{(T_{\text{max}} - T_{\text{min}})}{4\text{ °C/min}} + t_{\text{Haltezeit}} \right)$$

t_{Zyklus}	t_{cycle}
$\frac{T_{\text{max}} - T_{\text{min}}}{4\text{ °C/min}}$	$\frac{T_{\text{max}} - T_{\text{min}}}{4\text{ °C/min}}$
$t_{\text{Haltezeit}}$	$t_{\text{hold time}}$

7. In the example: $t_{\text{Zyklus}} = 2 \cdot \left(\frac{(105\text{ °C} - (-40\text{ °C}))}{4\text{ °C/min}} + 35\text{min} \right) = 142,5\text{ min}$

t_{Zyklus}	t_{cycle}
$\frac{105\text{ °C} - (-40\text{ °C})}{4\text{ °C/min}}$	$\frac{105\text{ °C} - (-40\text{ °C})}{4\text{ °C/min}}$
142,5 min	142.5 min

8. For 438 cycles, the total test duration is therefore 1 040 h.

E.4 Coffin-Manson model to be used for components on coolant circuits

For components with a connection to the coolant circuit, all relevant operating situations i (see section 4.3; " i " corresponds to the consecutive number of the situations) with their corresponding temperature rises for ambient temperature and coolant circuit temperature must be taken into account.

For the "Temperature cycle durability testing" service life test, the key temperatures and the number of test cycles must be calculated for each relevant operating situation i , as described below; the total number of test cycles is yielded from the sum of the partial numbers of test cycles for each relevant operating situation i .

For each relevant operating situation i , the numbers of test cycles for the ambient temperature and for the coolant circuit must first be calculated separately according to the Coffin-Manson model as per appendix C.7, in order to calculate the number of test cycles for operating situation i .

Because the resulting numbers of test cycles $N_{\text{test, ambient}}$ and $N_{\text{test, CC}}$ generally differ but the component can only be tested for the respective operating situation i with a uniform number of test cycles, the numbers of test cycles must be aligned between the ambient temperature and the coolant circuit.

The shorter of the two numbers of test cycles $N_{\text{test, ambient}}$ and $N_{\text{test, CC}}$ must be adapted to the longer number of test cycles using the following calculation, by dividing the test into three partial tests. One partial test is performed with a full temperature rise between T_{min} and T_{max} ; the other two partial tests are performed with a reduced temperature rise between T_{min} and T_{RT} , and between T_{RT} and T_{max} .

Case A: $N_{\text{test, ambient}} > N_{\text{test, CC}}$

Number of test cycles:

For $N_{\text{test, ambient}} > N_{\text{test, CC}}$, the number of test cycles for operating situation i is

$$N_{\text{test, mode } i} = N_{\text{test, ambient}}$$

Number of test cycles for coolant:

The number of test cycles for the coolant $N_{\text{test, CC}}$ must be adapted to the greater number of test cycles for the ambient temperature $N_{\text{test, ambient}}$. The test cycles must be performed in the following three temperature ranges:

1. x_{CC} test cycles must be performed between $T_{\text{CC, min}}$ and $T_{\text{CC, max}}$.
The acceleration factor $A_{\text{CM, CC, 1}}$ is calculated according to the Coffin-Manson model, with $\Delta T_{\text{test, 1}} = T_{\text{CC, max}} - T_{\text{CC, min}}$
2. $\frac{1}{2} * (N_{\text{test, mode } i} - x_{\text{CC}})$ test cycles must be performed between $T_{\text{CC, min}}$ and T_{RT} .
The acceleration factor $A_{\text{CM, CC, 2}}$ is calculated according to the Coffin-Manson model, with $\Delta T_{\text{test, 2}} = T_{\text{RT}} - T_{\text{CC, min}}$.
3. $\frac{1}{2} * (N_{\text{test, mode } i} - x_{\text{CC}})$ test cycles must be performed between T_{RT} and $T_{\text{CC, max}}$.
The acceleration factor $A_{\text{CM, CC, 3}}$ is calculated according to the Coffin-Manson model, with $\Delta T_{\text{test, 3}} = T_{\text{CC, max}} - T_{\text{RT}}$.

In total, $N_{\text{test, mode } i}$ temperature cycles are yielded from 1. to 3.

The following is yielded using equation (4) from appendix E.1:

$$N_{\text{TempCyclesField}} = x_{\text{CC}} \cdot A_{\text{CM,CC,1}} + \frac{1}{2} \cdot (N_{\text{test,mode},i} - x_{\text{CC}}) \cdot A_{\text{CM,CC,2}} + \frac{1}{2} \cdot (N_{\text{test,mode},i} - x_{\text{CC}}) \cdot A_{\text{CM,CC,3}}$$

The number of test cycles x_{CC} is calculated from this as follows:

$$x_{\text{CC}} = \frac{N_{\text{TempCyclesField}} - \frac{N_{\text{test,mode},i}}{2} \cdot (A_{\text{CM,CC,2}} + A_{\text{CM,CC,3}})}{A_{\text{CM,CC,1}} - \frac{1}{2} \cdot (A_{\text{CM,CC,2}} + A_{\text{CM,CC,3}})}$$

The numbers of test cycles for the three partial tests are obtained by introducing x_{CC} into points 1. to 3. listed above.

If $T_{\text{CC,op,max}} < T_{\text{CC,max}}$, or $T_{\text{CC,op,min}} > T_{\text{CC,min}}$, or $T_{\text{ambient,op,max}} < T_{\text{ambient,max}}$, or $T_{\text{ambient,op,min}} > T_{\text{ambient,min}}$, additional hold times at the corresponding temperatures as per Figure 47 in section 13.3.2.1 must be taken into account.

The temperature cycles for the ambient temperature and for the coolant circuit proceed synchronously during a test.

Case B: $N_{\text{test, ambient}} < N_{\text{test, CC}}$

Number of test cycles:

For $N_{\text{test, ambient}} < N_{\text{test, CC}}$, the number of test cycles for operating situation i is

$$N_{\text{test, mode } i} = N_{\text{test, CC}}$$

Number of test cycles for ambient temperature:

The number of test cycles for the ambient temperature $N_{\text{test, ambient}}$ must be adapted to the greater number of test cycles for the coolant $N_{\text{test, CC}}$. The test cycles must be performed in the following three temperature ranges:

1. x_{ambient} test cycles must be performed between $T_{\text{ambient,min}}$ and $T_{\text{ambient,max}}$. The acceleration factor $A_{\text{CM, ambient, 1}}$ is calculated according to the Coffin-Manson model, with $\Delta T_{\text{test, 1}} = T_{\text{ambient,max}} - T_{\text{ambient,min}}$.
2. $\frac{1}{2} \cdot (N_{\text{test, mode } i} - x_{\text{ambient}})$ test cycles must be performed between $T_{\text{ambient,min}}$ and T_{RT} . The acceleration factor $A_{\text{CM, ambient, 2}}$ is calculated according to the Coffin-Manson model, with $\Delta T_{\text{test, 2}} = T_{\text{RT}} - T_{\text{ambient,min}}$.
3. $\frac{1}{2} \cdot (N_{\text{test, mode } i} - x_{\text{ambient}})$ test cycles must be performed between T_{RT} and $T_{\text{ambient,max}}$. The acceleration factor $A_{\text{CM, ambient, 3}}$ is calculated according to the Coffin-Manson model, with $\Delta T_{\text{test, 3}} = T_{\text{ambient,max}} - T_{\text{RT}}$.

In total, $N_{\text{test, mode } i}$ temperature cycles are yielded from 1. to 3.

The following is yielded using equation (4) from appendix E.1:

$$N_{TempCyclesField} = x_{ambient} \cdot A_{CM,ambient,1} + \frac{1}{2} \cdot (N_{test, modei} - x_{ambient}) \cdot A_{CM,ambient,2} + \frac{1}{2} \cdot (N_{test, modei} - x_{ambient}) \cdot A_{CM,ambient,3}$$

The number of test cycles $x_{ambient}$ is calculated from this as follows:

$$x_{ambient} = \frac{N_{TempCyclesField} - \frac{N_{test, modei}}{2} \cdot (A_{CM,ambient,2} + A_{CM,ambient,3})}{A_{CM,ambient,1} - \frac{1}{2} \cdot (A_{CM,ambient,2} + A_{CM,ambient,3})}$$

The numbers of test cycles for the three partial tests are obtained by inserting $x_{ambient}$ into points 1. to 3. listed above.

If $T_{ambient, op, max} < T_{ambient, max}$, or $T_{ambient, op, min} > T_{ambient, min}$, or $T_{CC, op, max} < T_{CC, max}$, or $T_{CC, op, min} > T_{CC, min}$, additional hold times at the corresponding temperatures as per figure 45 in section 16.3.2.1 must be taken into account.

The temperature cycles for the ambient temperature and for the coolant circuit proceed synchronously during a test.

E.5 Example Coffin-Manson model to be used for components on coolant circuits

For an ECU connected to the coolant circuit, with the ambient temperature range $T_{\text{ambient, min}} = -40\text{ °C}$ to $T_{\text{ambient, max}} = 120\text{ °C}$ and the coolant temperature range $T_{\text{CC, min}} = -40\text{ °C}$ to $T_{\text{CC, max}} = 80\text{ °C}$, a service life in the field of 15 years, an average temperature difference of the ambient in the field of $\Delta T_{\text{field, ambient}} = 60\text{ K}$, and an average temperature difference of the coolant in the field of $\Delta T_{\text{field, CC}} = 36\text{ K}$, the number of test cycles for an operating situation i is calculated as follows:

Number of test cycles for ambient temperature and coolant temperature:

The calculation of the numbers of test cycles for the ambient temperature and for the coolant according to the Coffin-Manson model as per appendix E.1 supplies the following values:

$$N_{\text{test, ambient}} = 943 \text{ cycles}$$
$$N_{\text{test, CC}} = 540 \text{ cycles}$$

Because $N_{\text{test, ambient}} > N_{\text{test, CC}}$, the number of test cycles for operating situation i $N_{\text{test, mode } i} = N_{\text{test, ambient}} = 943 \text{ cycles}$. The number of test cycles for the coolant must be adapted.

Adapting the number of test cycles for the coolant:

The number of test cycles for the coolant is adapted to $N_{\text{test, mode } i} = 943 \text{ cycles}$ in three parts:

1. x_{CC} test cycles must be performed between $T_{\text{CC, min}} = -40\text{ °C}$ and $T_{\text{CC, max}} = 80\text{ °C}$. According to the Coffin-Manson model, this yields

$$\text{calculated acceleration factor } A_{\text{CM, CC, 1}} = \left(\frac{80\text{ °C} - (-40\text{ °C})}{36\text{ °C}} \right)^{2.5} = 20.29.$$

2. $\frac{1}{2} * (943 - x_{\text{CC}})$ test cycles must be performed between $T_{\text{CC, min}} = -40\text{ °C}$ and $T_{\text{RT}} = 23\text{ °C}$. According to the Coffin-Manson model, this yields

$$\text{calculated acceleration factor } A_{\text{CM, CC, 2}} = \left(\frac{23\text{ °C} - (-40\text{ °C})}{36\text{ °C}} \right)^{2.5} = 4.05.$$

3. $\frac{1}{2} * (943 - x_{\text{CC}})$ test cycles must be performed between $T_{\text{RT}} = 23\text{ °C}$ and $T_{\text{CC, max}} = 80\text{ °C}$. According to the Coffin-Manson model, this yields

$$\text{calculated acceleration factor } A_{\text{CM, CC, 3}} = \left(\frac{80\text{ °C} - 23\text{ °C}}{36\text{ °C}} \right)^{2.5} = 3.15.$$

This yields the following for x_{CC} :

$$x_{CC} = \frac{N_{TempCyclesField} - \frac{N_{test, mode i}}{2} \cdot (A_{CM, CC, 2} + A_{CM, CC, 3})}{A_{CM, CC, 1} - \frac{1}{2} \cdot (A_{CM, CC, 2} + A_{CM, CC, 3})} = \frac{10\,950 - \frac{943}{2} \cdot (4.05 + 3.15)}{20.29 - \frac{1}{2} \cdot (4.05 + 3.15)} = 453 \text{ cycles}$$

Therefore, the following numbers of test cycles calculated as per points 1. to 3. are yielded for the three temperature ranges:

1. Between $T_{CC, \min} = -40 \text{ °C}$ and $T_{CC, \max} = 80 \text{ °C}$, 453 cycles must be performed.
2. Between $T_{CC, \min} = -40 \text{ °C}$ and $T_{RT} = 23 \text{ °C}$, 245 cycles must be performed.
3. Between $T_{RT} = 23 \text{ °C}$ and $T_{CC, \max} = 80 \text{ °C}$, 245 cycles must be performed.

Adding the partial test cycles again yields the total number of test cycles for operating situation i $N_{test, mode i} = 943$ cycles.

The temperature cycles for the ambient temperature and for the coolant circuit proceed synchronously during a test.

Appendix F (normative)

Calculation models for the "Damp heat, constant – severity 2" test

F.1 Lawson model

The calculation of the test duration for the "Damp heat, constant – severity 2" test is based on the average ambient humidity $RH_{\text{FieldParking}}$ and the average ambient temperature $T_{\text{FieldParking}}$ of the component in the parked vehicle.

Unless otherwise defined in the Performance Specification, the following values must be used for the calculation:

Table 113: Average ambient humidity and ambient temperature in the parked vehicle

Point of use	Average ambient humidity $RH_{\text{FieldParking}}$	Average ambient temperature $T_{\text{FieldParking}}$
In the passenger compartment/luggage compartment	60% relative humidity	23 °C
Outside the passenger compartment/luggage compartment	65% relative humidity	23 °C

The acceleration factor of the Lawson model is calculated as follows, as a function of the average ambient humidity and ambient temperature in the field:

$$A_{T/RH} = e^{\left[-\left(\frac{E_A}{k} \right) \left(\frac{1}{T_{\text{test}} + 273.15} - \frac{1}{T_{\text{FieldParking}} + 273.15} \right) \right]} + b \left[(RH_{\text{test}})^2 - (RH_{\text{FieldParking}})^2 \right] \quad (5)$$

where:

$A_{T/RH}$	Acceleration factor of the Lawson model
b	Constant ($b = 5.57 \cdot 10^{-4}$)
E_A	Activation energy ($E_A = 0.4 \text{ eV}$)
k	Boltzmann constant ($k = 8.617 \times 10^{-5} \text{ eV/K}$)
T_{test}	Test temperature in °C
$T_{\text{FieldParking}}$	Average ambient temperature in °C
RH_{test}	Relative humidity in % during the test
$RH_{\text{FieldParking}}$	Average relative humidity in %
-273.15 °C	Absolute zero of temperature

The test duration for the "Damp heat, constant – severity 2" test is calculated using the following equation:

$$t_{\text{test}} = \frac{t_{\text{FieldParking}}}{A_{T/RH}} \quad (6)$$

where:

t_{test}	Test duration in h
$t_{\text{FieldParking}}$	Non-operating duration (parking duration) in h during the service life in the field (131 400 h in the worst-case scenario if the vehicle is not used)
$A_{T/RH}$	Acceleration factor of the Lawson model as per equation (5)

F.2 Example:

For an ECU installed in the engine compartment, the test duration is calculated as follows:

1. For the component, an average temperature of $T_{\text{FieldParking}} = 23\text{ °C}$ and a relative humidity of $\text{RH}_{\text{FieldParking}} = 65\%$ in the parked vehicle are assumed.
The test conditions are $T_{\text{test}} = 65\text{ °C}$ and $\text{RH}_{\text{test}} = 93\%$.

Using equation (5), these values yield a combined acceleration factor of the Lawson model of $A_{T/\text{RH}} = 82.5$.

2. The parking duration in the field is $t_{\text{FieldParking}} = 131\,400\text{ h}$.
Using equation (6), this yields a total test duration of:

$$t_{\text{test}} = \frac{131\,400\text{ hours}}{82.5} = 1\,593\text{ hours}$$

Appendix G (informative)

Condensation test, chamber programming, and graphs

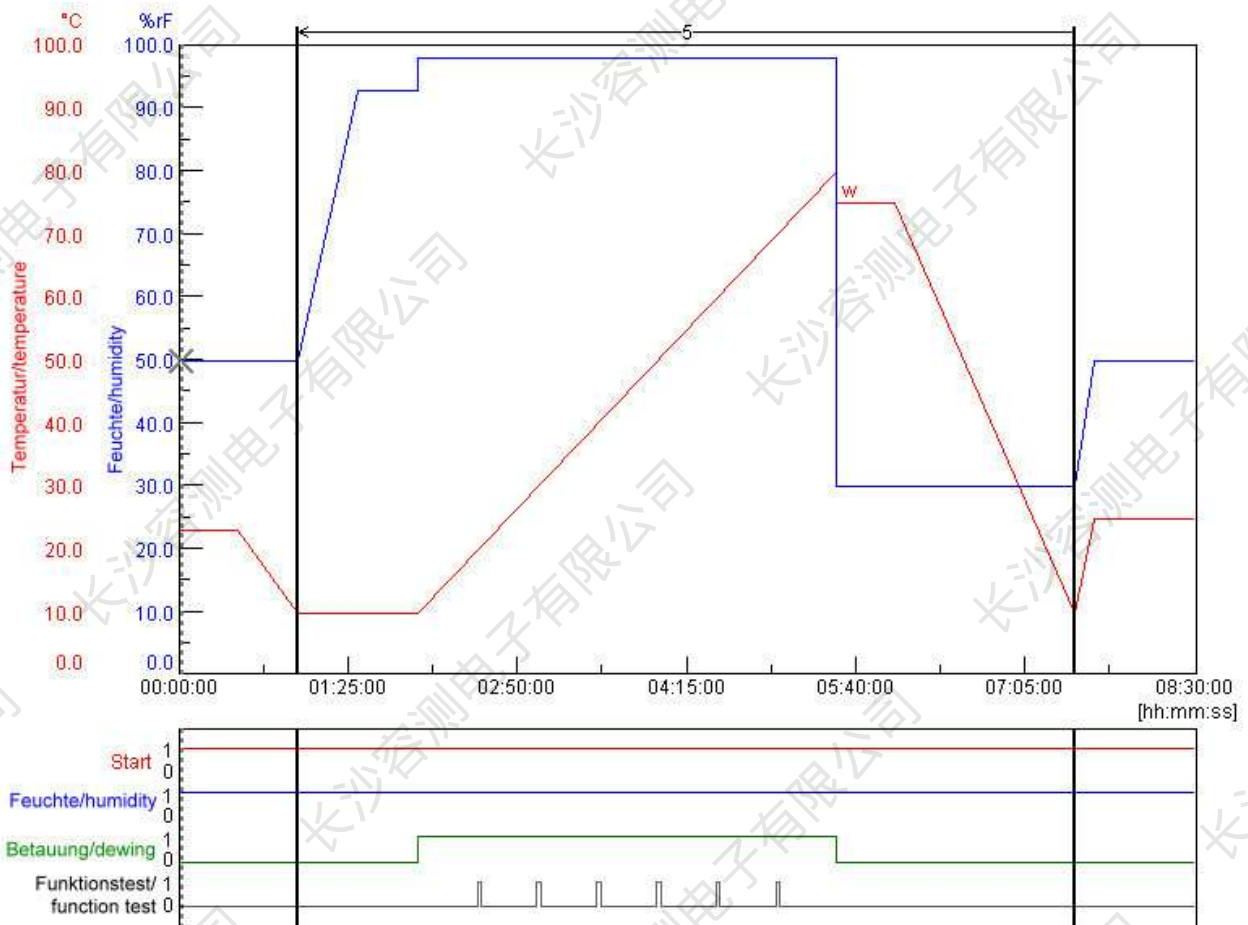

Figure 52: Programming of the test chamber

During the temperature increase, the temperature of the water bath is used as the control variable. When 80 °C is reached, the climatic chamber is switched over to temperature control (standard operation).

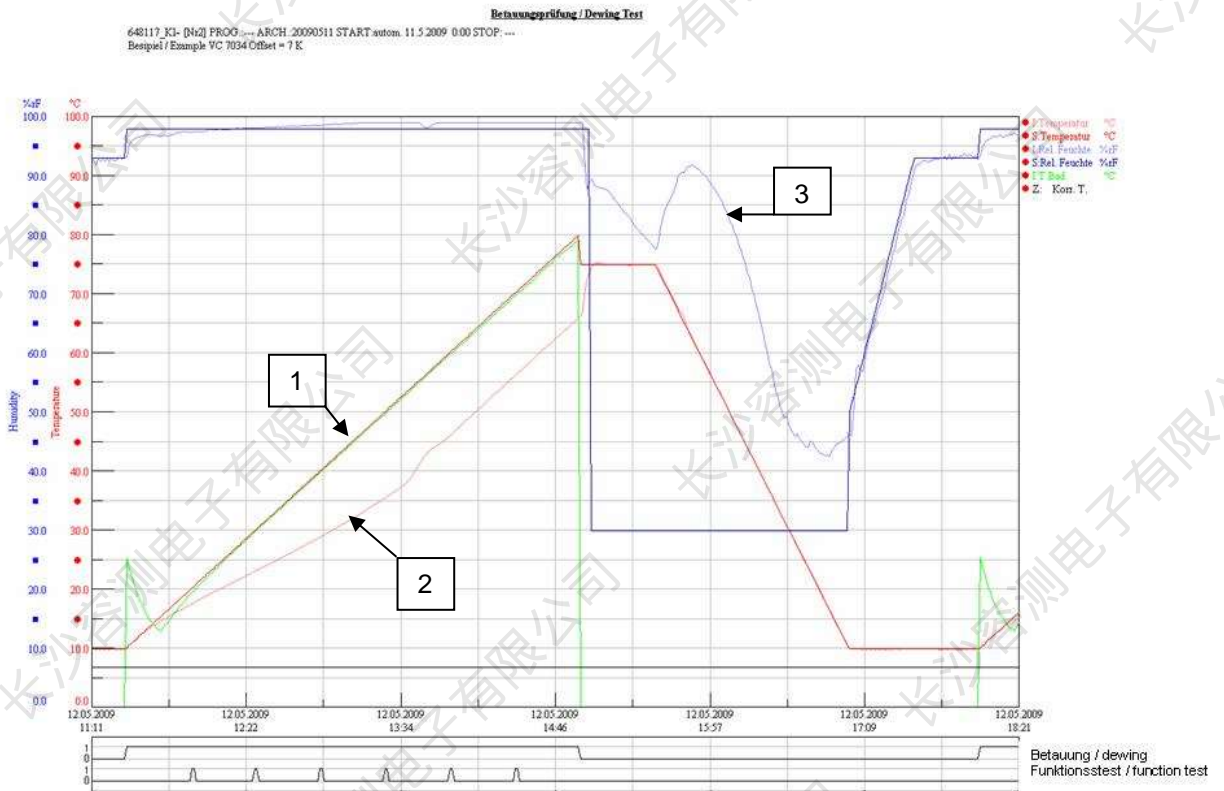

Figure 53: Sequence of the condensation test, 1 cycle

I: Temperatur	°C	Actual temperature	°C
S: Temperatur	°C	Desired temperature	°C
I: Rel. Feuchte	%rF	Actual rel. humidity	%RH
S: Rel. Feuchte	%rF	Desired rel. humidity	%RH
I: T Bad	°C	Actual bath temp.	°C
Z: Korr. T.		Z: Corr. temp.	

1. Controlled water bath temperature
2. Resulting test chamber temperature
3. Actual humidity in the test chamber

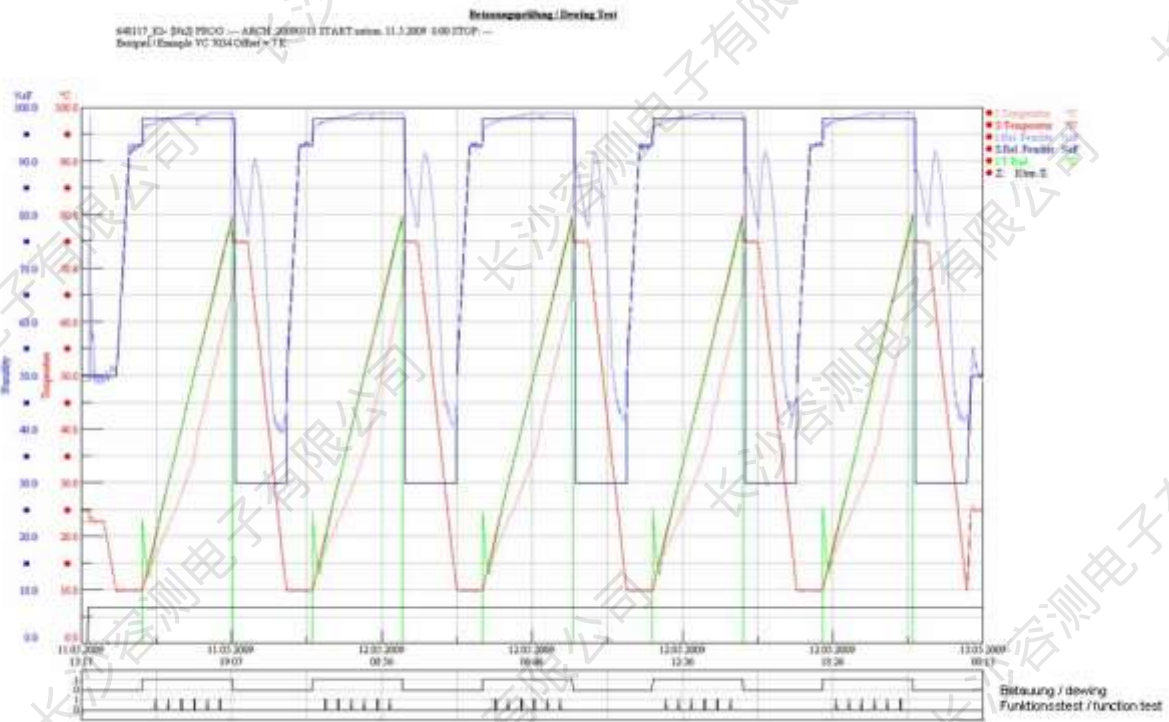

Figure 54: Sequence of the condensation test, 5 cycles

I: Temperatur	°C	Actual temperature	°C
S: Temperatur	°C	Desired temperature	°C
I: Rel. Feuchte	%RH	Actual rel. humidity	%RH
S: Rel. Feuchte	%RH	Desired rel. humidity	%RH
I: T Bad	°C	Actual bath temp.	°C
Z: Korr. T.		Z: Corr. temp.	

Appendix H

Examination methods for physical analysis

- Residual torques (e.g., housing threaded connection, fastening screws on the shaker table)
- Solder joint flaws
- Subcomponent/PCB discolorations (especially due to thermal causes)
- Rough/smooth running, grinding, play (for mechanically moving parts)
- Traces of abrasion
- Jumps, cracks, deformation of materials (especially in potting and sealing compounds). A suitable test method (x-ray, computed tomography (CT), microsections, etc.) must be selected by mutual agreement.
- Opacity (especially for parts in optical sensor systems)
- State of latches and clips
- Traces of corrosion and migration
- Evaluation of plastics for hydrolysis resistance (especially for components with inserted lead frames and t.30 circuitry)
- Damage to vias of PCBs, especially thermal vias
- Damage to the internal connection (paddles) of large electrolytic capacitors after mechanical load (vibration, mechanical shock, drop test)
- Connector pin damage (e.g., due to current, temperature, rubbing, oxidation)
- Other irregularities
- Result of in-circuit test (ICT)
- Evaluation of sealing surfaces for corrosion creepage:
 - Corrosion creepage is generally impermissible.
 - Corrosion creepage of $\leq 50\%$ of the sealing surface must be jointly evaluated with the purchaser.



Figure 55: Sealing geometries